



**CONTROL DE TEMPERATURA  
Y MEDICIÓN**



**ELECTRICAL HEATING AND COOLING  
SOLUTIONS  
FOR THE INDUSTRY**



# VULCANIC

The Vulcanic group has been designing and manufacturing electrical process heating and temperature control solutions since 1973. Employing 550 people across 8 manufacturing locations, Vulcanic currently services 30 000 customers in 100 different countries across the globe and is an ISO 9001 v 2008 accredited company.



**You have an issue... let us solve it !  
Vulcanic your worldwide local partner !**



**Advice**

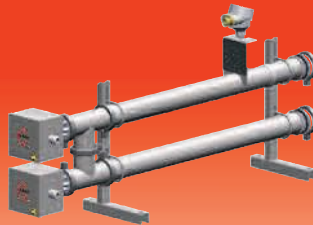

**Design**



**Manufacturing**

## All in One Solutions

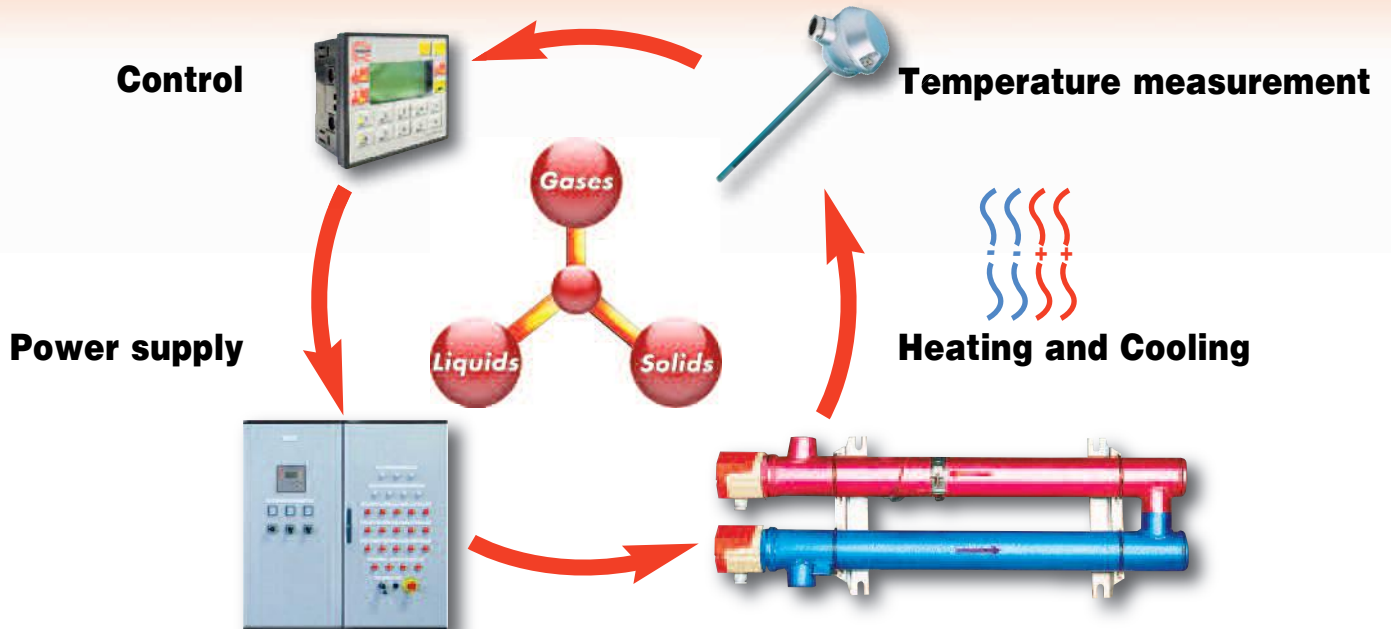





## SERVED MARKETS



## DESIGN EXPERTISE AND CODES

Vulcanic design teams support our partners from conceptual design and feasibility study throughout the life of the equipment. Our design capabilities include:

- Electrical design
- Mechanical design
- Thermal design
- Electronic design (hardware and software)
- Hydraulic design
- Automation
- Communication protocols
- Hazardous area certification



- AD 2000
- ASME
- CODAP
- EN 286

- PD 5500
- RCC-M / RCC-E
- STOOMWEZEN
- GOST



# MANUFACTURING

Vulcanic offers the benefits of integrated "in house" manufacturing processes, using "state of the art" equipment to manufacture almost all components utilised within our product ranges. With only minimal dependance upon subcontractors, we remain in full control of Quality and Production schedules while maintaining a high level of know how in house.



Heating element manufacturing



CNC machining



Sensor manufacturing



Welding



Wiring

# CERTIFICATION



- ISO 9001 : 2008
- PED 97/23/EC cat I-IV
- ATEX 94/9/EC
- IECEx
- TR CU
- CCOE
- VDE
- UL
- DNV
- INMETRO







# VULCANIC GROUP

**VULCANIC SAS**  
ZI des Chanoux  
48, rue Louis Ampère  
F-93330 Neuilly sur Marne  
France  
Tel. : +33 1 49 44 49 20



**VULCANIC SAS**  
ZI la Saunière  
F-89600 Saint Florentin  
France  
Tel. : +33 1 49 44 49 20



**VULCANIC UK Ltd**  
South Green Park  
Entreprise Centre, Mattishall  
NR20 3JY, Dereham Norfolk  
United Kingdom  
Tel. : +44 1603 340015



**LOREME SAS**  
12, rue des Potiers d'Etain  
Actipôle Borny  
F-57071 Metz  
France  
Tel. : +33 3 87 76 32 51



**VULCANIC SA**  
Heilig Hartstraat, 14  
B-2600 Berchem  
Belgium  
Tel. : +32 3 286 70 30



**RS ISOLSEC SAS**  
45, avenue des acacias  
F-45120 Cepoy  
France  
Tel. : +33 2 38 85 62 62



**VULCANIC TERMOELÉCTRICA SLU**  
Ctra. a Viérnoles, 32  
E-39300 Torrelavega  
Spain  
Tel. : +34 942 80 35 35



**VULCANIC GmbH**  
Donaustraße 21  
D-63542 Hanau  
Germany  
Tel. : +49 6181 9503 0



**RS ISOLSEC SLU**  
Ave Riu Mogent, 5  
E-08170 Montornes del valles  
Spain  
Tel. : +34 93 568 73 10



**VULCANIC Russia**  
105005 Moscow  
radio street  
house 24 building 1  
Russia  
Tel. : + 7 (903) 967-95-68



**VULCANIC TRIATHERM GmbH**  
Flurstraße 9  
D-96515 Sonneberg  
Germany  
Tel. : +49 3675 4083-0



# TEMPERATURE MEASUREMENT AND CONTROL

Thermostats and temperature safety cut outs

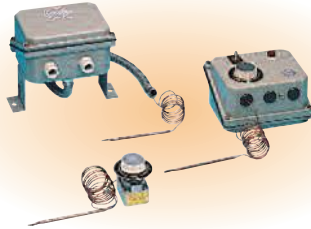

Hydrometers

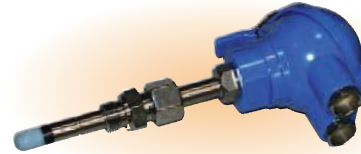

Electromechanical thermostats



PT 100 Sensors

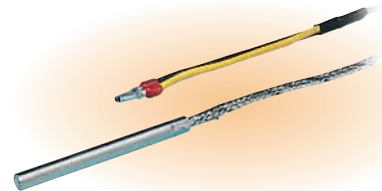

Thermocouple probes



Converters



Sealing glands



Controllers and displays



Solids state relays



Control units



notes :  
 - The NC contacts open when the temperature rises, while the NO contacts close when the temperature rises.  
 - The differential is the temperature difference between the operating point of the thermostat and the level where the contacts return to their original state.

## THERMOSTATS WITHOUT FITTINGS

Liquid expansion type, copper capillary and bulb.  
 Double-pole double-throw contacts,  
 16 A at 400 VAC.  
 Accuracy  $\pm 1\%$  of full scale.  
 Differential 2,5% of full scale.

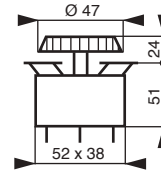

P/N.	Range (°C)	Bulb Ø (mm)	Bulb length (mm)	Capillary length (mm)	Weight (kg)
9014-04	0-100	8	100	1500	0,16
9014-05	50-200	5	150	1500	0,16
9014-03	0-300	5	100	1500	0,16
9014-07	0-300	5	120	3000	0,17

Steam pressure thermostats, with stainless steel 1m long capillary.  
 Single-pole double-throw contacts, 16A at 250 VAC  
 6mm Ø bulb. Small in size but with an excellent breaking capacity, these thermostats fit easily into control boxes.  
 They are the most cost-effective solution for temperature control.

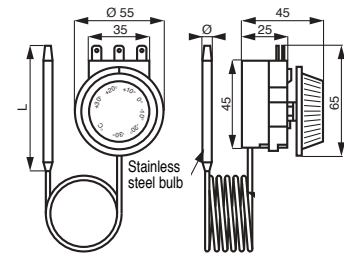

P/N.	Range (°C)	Accuracy (°C)	Differential (°C)	Bulb Ø (mm)	L (mm)	Weight (kg)
9030-51	-30/+30	+/-4	4	6	130	0,1
9030-52	0/120	+/-5	4	5	80	0,1

P/N.	Range (°C)	Accuracy (°C)	Differential (°C)	Bulb Ø (mm)	L (mm)	Weight (kg)
9030-53	0/200	+/-5	10	5	90	0,1
9030-54	50/320	+/-15	10	3	160	0,1

Capillary thermostats.  
 Single-pole double-throw contacts, breaking capacity 16A at 400V .  
 Copper bulb, Ø 6 mm.  
 Copper capillary, length 1000mm.

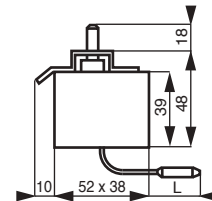

P/N.	Range (°C)	Differential (%)	Bulb length (mm)	Weight (kg)
9030-02	0-100	2,5	140	0,23
9030-03	50-300	2,5	90	0,23

Identical model but without setting knob or stem. Adjustment by screw driver.

P/N.	Range (°C)	Differential* (%)	Bulb length L (mm)	Weight (kg)
9030-08	0-100	2,5	140	0,23

Liquid expansion type, copper bulb and capillary.  
 Single-pole double-throw contacts, 10 A at 230 VAC.  
 Accuracy  $\pm 1\%$  of full scale.

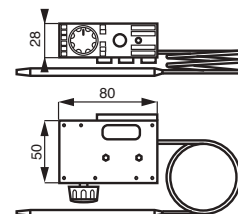
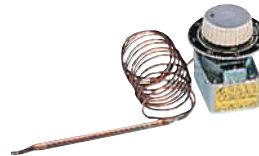

P/N.	Range (°C)	Bulb Ø (mm)	Bulb length (mm)	Capillary length (mm)	Weight (kg)
9030-07	110/550	4	120	1470	0,16

Capillary thermostat.  
 Single-pole double-throw contacts, breaking capacity 10 A at 250V.  
 Copper bulb, Ø 6 mm.  
 Copper capillary, length 1 m.

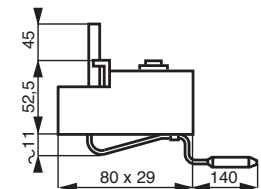
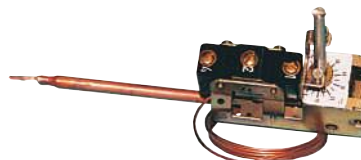

P/N.	Range (°C)	Differential (%)	Weight (kg)
9030-01	0-70	4	0,15

\* % of full scale.



## POSITIVE SAFETY TEMPERATURE CUT-OUTS WITH ADJUSTABLE THRESHOLD

Designed to protect water-heating installations against overheating, these temperature cut-outs are adjustable between 90° to 110°C and are manually reset.

They are fitted with a 1m long capillary and a 6,5x90 mm bulb.

Circuit is open if the sensor is broken.

Single-pole normally close contacts, breaking capacity 15A at 230V.

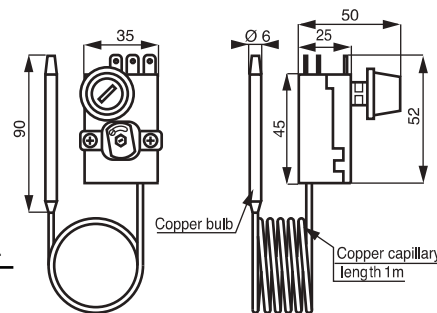
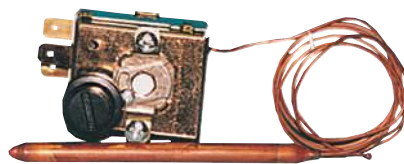

P/N.	Cut-out temp.	Cut-out tolerance	Max. bulb temp.
9030-31	90/110°C	+0°C/-6°C	120°C

## THREE PHASE SAFETY TEMPERATURE CUT-OUT THERMOSTAT

Liquid expansion type thermostat including a safety temperature cut-out function with manual reset.

Temperature range +15°C to +85°C.

Safety temperature pre-set to 110°C.

Triple-pole normally close contacts, breaking capacity 3x20A at 400V.

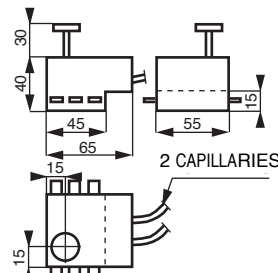
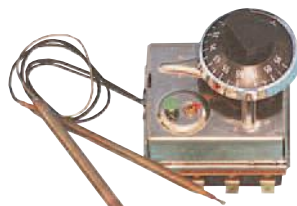

P/N.	Thermostat	Range (°C)	Bulb Ø (mm)	Bulb length (mm)	Capillary length (mm)
9014-13	Thermostat	+15/+85	6	95	900
	Safety temp	Fixed at 110°C	6	120	900

## ENCLOSED ROD-TYPE THERMOSTATS

Simple to install and use, these box-mounted liquid-expansion thermostats are fixed to the tank (or pipe) and heated via the supplied copper thermowell.

IP40 box.

Copper probe, length 95mm.

Single-pole double-throw contacts, breaking capacity 15A at 250VAC, 10A at 400VAC.

Differential 6°K,

Accuracy ±3°C,

Max. working pressure: 10 bar.

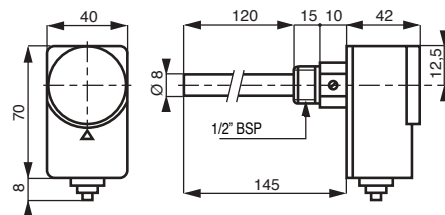
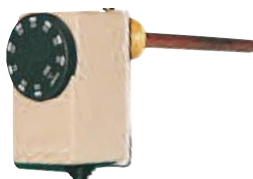

P/N.	Range (°C)	Max. bulb temp.
9030-11	10/90	120
9030-12	40/120	150

## ENCLOSED ROD-TYPE POSITIVE SAFETY TEMPERATURE CUT-OUTS

These positive safety temperature cut-outs, (box mounted), with manual reset, are used to protect water heating systems against overheating. Circuit is open if the sensor is broken.

Simple to install and use, these box-mounted liquid-expansion thermostats are fixed to the tank (or pipe) and heated via the supplied copper thermowell.

IP40 box.

Copper probe, length 95mm.

Single-pole double-throw contacts, breaking capacity 15A at 250V, 10A at 400V

Differential 6°K, . Max. working pressure : 10 bar.

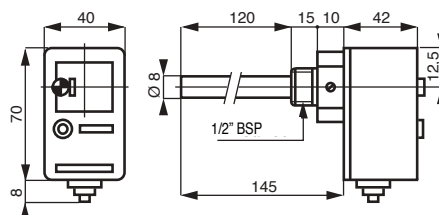

P/N.	Cut-out temp.	Cut-out Accuracy	Max. bulb temp.
9030-21	100°C	+0°C/-6°C	120°C

## ENCLOSED THERMOSTATS AND POSITIVE SAFETY TEMPERATURE CUT-OUTS

Box containing a adjustable thermostat between 10°C to 90°C and a temperature cut-out, pre-set to 100°C, with manual reset.

Circuit is open if the sensor is broken.

Simple to install and use, these box-mounted liquid-expansion thermostats are fixed to the tank (or pipe) and heated via the supplied copper thermowell.

IP40 box.

Copper probe, length 95mm.

Thermostat : single-pole double-throw contacts, breaking capacity 15A at 250V, 10A at 400V.

Cut-out : normally close contact

Differential 6°K, Max. working pressure : 10 bar.

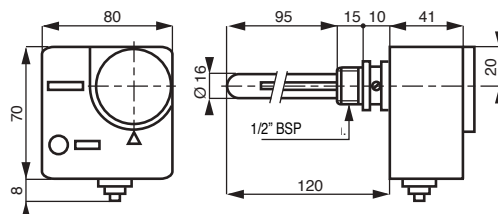
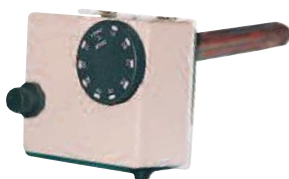

P/N.	Cut-out temp.	Cut-out tolerance	Max. bulb temp.
9030-41	100°C	+0°C/-6°C	120°C



## ENCLOSED THERMOSTATS

Liquid expansion type, copper bulb and capillary.  
Double-pole double throw contacts, 16A at 400VAC.  
Accuracy  $\pm 1\%$  of full scale.  
Differential 2,5% of full scale.  
Adjusting knob accessible by removal of the cover.

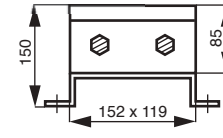

P/N.	Range (°C)	Bulb Ø (mm)	Bulb length (mm)	Capillary length (mm)	Weight (kg)
9019-02	0-100	8	100	1500	2
9019-03	50-200	5	150	1500	2
9019-01	0-300	5	100	1500	2

Protected enclosed models, with double-poles double-throw switch and heating indicator light.  
Voltage 230V 1P (3500W max.).  
Optional 230V 3P supply (6000W max.).

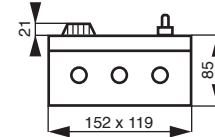

P/N.	Range (°C)	Bulb Ø (mm)	Bulb length (mm)	Capillary length (mm)	Weight (kg)
9014-06	0-100	8	100	1500	1
9014-08	50-200	5	150	1500	1
9014-09	0-300	5	100	1500	1

## THERMOSTATS FOR HEATING TAPES

Liquid expansion type thermostat for heating cables, in an IP 55 box fitted with fixing lugs on the insulating cover, with copper capillary.  
Single-pole double-throw open contact, 16A at 400VAC. Gland : ISO 16 BIS and ISO 20 BIS

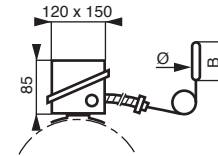

P/N.	Range (°C)	Ø (mm)	B (mm)	Capillary length (mm)	Weight (kg)
9014-11	+30 +110	8	90	1000	2
9014-12	-20 +30	8	143	1000	2

Spare thermostats:

P/N.	Range (°C)	Ø (mm)	B (mm)	Capillary length (mm)	Weight (kg)
9014-31	+30 +110	8	90	1000	2
9014-32	-20 +30	8	143	1000	2

## ATEX/IECEX AMBIENT AIR THERMOSTAT «GAS AND DUST» - Ex de - IP65

These ATEX thermostats are certified for zone 1 with an ambient temperature from -40°C up to 40°C (T6) or -40°C à +50°C (T4).

Protection: Ex de IIC T6 (T3 on request)

Junction box: IP 65

Dimensions: 122x120x90 mm

Breaking capacity: 10A/230VAC

Atex marking: II 2 G Ex d e IIC T6 Gb or II 2 G Ex d e IIC T4 Gb for hazardous atmospheres

and II 2 D Ex tb IIIC T85° Db et II 2 D Ex IIC T130 Db for explosive ambient with conductive dust.

Certificate: EPS 11 ATEX 1 354



Ambiance

Contact/surface

P/N.	Range (°C)	Ø (mm)	Type	Weight (kg)
6023-02	-20/+40 (T6)	70	Ambient	0,6
6023-03	0/+50 (T6)	1000	Contact/surface	0,6
6023-04	0/+120 (T4)	1000	Contact/surface	0,6

## EXTRA-LONG THERMOSTATS

Extra-long steam pressure thermostat in a stainless steel thermowell, with IP 55 cover.

Double-pole double-throw contacts, breaking capacity 16A at 400VAC.

Specially designed for type 4910 suction filter heaters, see immersion heater section

Accuracy  $\pm 3\%$  of full scale.

Supplied with a fixing gland.

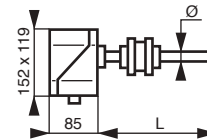

P/N.	Range (°C)	Ø (mm)	L (mm)	Weight (kg)
9010-01	0-300	12	3000	3

Note : Cutting to length L can be done within a short delivery time to suit the exactly dimensions of your tank

## ROD TYPE THERMOSTATS

Liquid expansion type thermostat with a 6mm Ø probe in a removable stainless steel thermowell, with an IP 54 cover.

Differential 2,5% of full scale.

Double-pole double-throw contacts, 10A at 230V.

To install these thermostats you need only a 1/2" BSP threaded hole in the recipient tank. The sealable cover is fixed to the thermowell by a retaining screw, and the bulb can easily be removed.

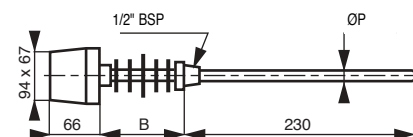

P/N.	Range (°C)	ØP (mm)	B (mm)	Weight (kg)	Fig.
9008-11	0-100	8	19	0,56	I
9008-12	0-150	8	19	0,56	I
9008-13	50-300	8	84	0,76	J

## AMBIENT AIR THERMOSTATS

Simple model designed for temperature control in rooms or air-conditioned enclosures. Normally close contact, breaking capacity 10A at 250VAC. Differential 0,6°C.

Suitable for outdoor use, for frost protection of water tanks, pipes, pools... Sealable IP 55 cover. Normally close contact, breaking capacity 10A at 250VAC. Differential 3°C.

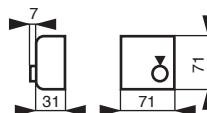

P/N.	Range (°C)	Weight (kg)
9014-20	5/30	0,12

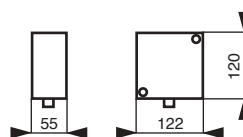

P/N.	Range (°C)	Weight (kg)
9014-23	-20 / +30	0,41

## SAFETY CUT-OUTS WITH ADJUSTABLE THRESHOLD

Temperature limiter, liquid expansion type with capillary. Single-pole double-throw contacts, breaking capacity 16A at 400VAC. Manual reset. Stainless steel capillary, length 1 m and stainless steel bulb, diameter 6 mm.

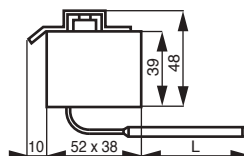
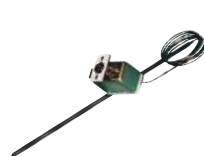

P/N.	Range (°C)	Bulb L (mm)	Weight (kg)
9030-05	+50 +300	85	0,15
9030-06	+20 +500	300	0,15

## PRE-SET SAFETY TEMPERATURE LIMITERS

Temperature limiter, bimetallic expansion type with automatic reset, for air temperature alarms. Normally close contact, breaking capacity 10A at 250VAC. Differential 12°C.

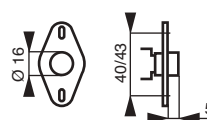

P/N.	Cut-out temp.	Weight (kg)
53691-01	90°C	0,01
9009-01	110°C	0,01

Temperature limiter, positive safety steam pressure type, with automatic or manual reset. Capillary Ø 1,9 mm, length 1 m. Normally close contact, breaking capacity 16A at 250VAC. Differential 12°C.

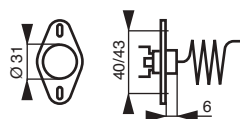

P/N.	Cut-out temp.	Reset	Weight (kg)
54229-01	90°C	auto.	0,05
53710-01	90°C	manu.	0,05

## TIMERS

This timer allows two electrical appliances to be switched on and off independently according to a daily and weekly cycle. 42 switching orders can be programmed for any time over a maximum period of a week. Minimum programming interval : 1 minute. Digital display giving hour, working state and programming.

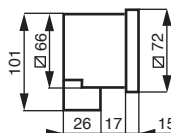

P/N.	Voltage (V)	Weight (kg)
9025-12	230V 50 Hz	0,2

Quick summer/winter time changeover. Backup in case of power cuts : 150 hours max.  
double throw open contacts : 16A at 250VAC  
Resistive load.

## THERMO HYGROMETER

Humidity transmitter 40 HRG for air duct heater, robust design, measures the relative humidity and provides information through an output signal of 4/20 mA with 2 wires. HRG 40 is suitable for use in harsh environments (saline atmosphere and nitric acids, sulfuric, hydrochloric up to 75000 ppm). Max operating Humidity 93%  
Digital measurement (sensor included) ensures excellent repeatability and excellent performance characteristics

- Cast aluminium box with epoxy coating with sealing gland.
- Closing by clip or screw closure (IP 54 or 65)
- Stainless steel 316 dipping tube (Ø = 13,5mm)
- Pressure holding: 2 bars.
- Humidity hysteresis : +/- 1,5%
- Supply voltage 9 to 36 Vdc by 2 wires with protection against reverse polarity.
- Possibility to unplug the sensitive element
- Version with display is available on request (LCD 4 digits- 10000 points resolution)



P/N.	Max Temp.	Screw plug sliding
30746-01	60 °C	1/2" BSPP
30746-02	60 °C	1/2" BSPT
30746-01	60 °C	1/2" NPT

## ELECTRO-MECHANICAL THERMOSTATS WITH FIXING FLANGE

These thermostats can easily be fixed to ventilation ducts and oven walls to monitor air and gas temperatures.

Max. pressure : 100 mm WC

Breaking capacity on resistive load :

- 5/8" models:

10 A at 115 VCA, 5A at 230 VCA, 2 A at 115 VCC.

- 1/2" models:

5 A at 115 VCA, 3 A at 230 VCA, 1 A at 115 VCC.

- 1/4" models:

1A at 115 VCA

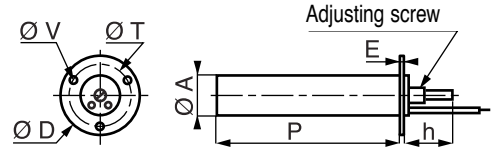

Not pre-set

P/N	Ø A	Temp. Range	Contact	P (mm)	h (mm)	E (mm)	Ø D (mm)	Ø T (mm)	Ø V (mm)	Model	Type
8310-00	5/8"	-70/+315°C	NC	84,1	27	1,6	44,5	31,8	4	Standard	8311
8320-00	5/8"	-70/+315°C	NO	84,1	27	1,6	44,5	31,8	4	Standard	8321
8330-00	1/2"	-70/+315°C	NC	58,7	23,9	1,6	44,5	31,8	4	Standard	8331
8340-00	1/2"	-70/+315°C	NO	58,7	23,9	1,6	44,5	31,8	4	Standard	8341

To order a pre-set thermostat state type P/N. followed by the required temperature.

Example : Type 8311 pre-set to 130°C.

## ELECTRO-MECHANICAL THERMOSTATS IN IP65 SEALED BOX - 1 OR 2 GLANDS

These thermostats are ideally suited to applications involving liquids, solids or gases where the measuring side and the connection side have to be sealed.

Max. pressure : 20 bar.

Breaking capacity on resistive load :

- 5/8" models:

10 A at 115 VCA, 5A at 230 VCA, 2 A at 115 VCC.

- 1/2" models:

5 A at 115 VCA, 3 A at 230 VCA, 1 A at 115 VCC.

Aluminium alloy box with N°16 gland for cables of min.Ø 10 mm, max.Ø 15 mm.

Closure by captive screw.

Options :

Epoxy-coated box.

Protective resistance.

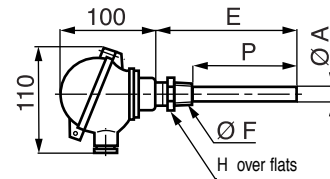

Not pre-set

Models with only one gland

P/N	Ø A	Temp. Range	Contact	P (mm)	E (mm)	Ø F	H (mm)	Model	Type
8350-00	5/8"	-70/+315°C	NC	76,2	100	1/2" NPT	23	Standard	8351
8360-00	5/8"	-70/+315°C	NO	76,2	100	1/2" NPT	23	Standard	8361

The 2nd gland allows series or parallel connection of several thermostats.

Not pre-set

Models with 2 glands

P/N	Ø A	Temp. range	Contact	P (mm)	E (mm)	Ø F	H (mm)	Model	Type
8410-00	5/8"	-70/+315°C	NC	76,2	100	1/2" NPT	23	Standard	8411
8420-00	5/8"	-70/+315°C	NO	76,2	100	1/2" NPT	23	Standard	8421

To order a pre-set thermostat state type P/N. followed by the required temperature.

Example : Type 8351 pre-set to 130°C.

## ELECTRO-MECHANICAL THERMOSTATS - Ex d - IP65 - 1 or 2 GLANDS

These thermostats are ideally suited for use in hazardous atmospheres, gas or liquids.

Marking : .II 2 G Ex d IIC T1 to T6 .

Breaking capacity on resistive load :

- 5/8" models:

10 A at 115 VCA, 5A at 230 VCA, 2 A at 115 VCC.

- 1/2" models:

5 A at 115 VCA, 3 A at 230 VCA, 1 A at 115 VCC.

Aluminium alloy box with integral ADF gland for cables of min.Ø 10 mm, max.Ø 19 mm.

Option :

Epoxy-coated box.

Earth terminal.

Protective resistance.

Certificate LCIE 03 ATEX 6339

Usable in hazardous areas (ambient temperature mini -20°C, relative humidity 95 % maximum).

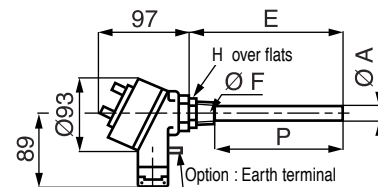

ATEX :

CE 0081 Ex II 2 G Ex d IIC T1 to T6

Not pre-set

Models with only one gland

P/N	Ø A	Temp. range	Contact	P (mm)	E (mm)	Ø F	H (mm)	Model	Type
8450-00	5/8"	-70/+315°C	NC	76,2	100	1/2" NPT	23	Standard	8451
8460-00	5/8"	-70/+315°C	NO	76,2	100	1/2" NPT	23	Standard	8461

Not pre-set

Models with 2 glands

P/N	Ø A	Temp. range	Contact	P (mm)	E (mm)	Ø F	H (mm)	Model	Type
8452-00	5/8"	-70/+315°C	NC	76,2	100	1/2" NPT	23	Standard	8453
8462-00	5/8"	-70/+315°C	NO	76,2	100	1/2" NPT	23	Standard	8463

To order a pre-set thermostat state type P/N. followed by the required temperature.

Example : Type 8453 pre-set to 130°C.



A temperature sensor is generally a small diameter cylinder (between 0.5 and 8 mm), varying in length (between 50 mm and several meters), rigid or deformable and immersed in the media to be measured : solid, liquid or gas. The choice depends on the following criteria: temperature range, precision, response time, media to be measured, overall dimensions, pressure, corrosion, attachment and connection.

**The NTC technology (thermistor)** is used predominantly for domestic applications based on the ambient temperature (-80° to 150°C).

**The PTC technology (PT 100)** is suited to industrial applications between -50°C and 500°C, in the absence of excessive vibration.

**The thermocouple technology** allows very short response times and high temperatures but with a lower precision (+/- 2°C on average).

The electrical connection of the sensors is made either using flexible cables or connectors, or on a terminal block inside a small standardised metal case referred to as the "probe head". When the cable is particularly long, it is advisable to use a 4/20 mA measurement converter installed in the probe head.

Some connection devices are ATEX certified in the "d", "e" or "ia" protection modes in a G (gas) or D (dust) environment.

The fastening of a sensor is done by a welded or swaged coupling, a sliding flange or by a bracket integrated in a case.

The use of a thermowell allows easy replacement of the sensor, its use in particularly corrosive environments and better resistance to high-pressure levels.

The mineral insulated cables are deformable. Generally long, they can be shrunk at the ends to benefit from a better response time.

## PTC TECHNOLOGY ( PT 100 )

A PT 100 probe is a resistor whose value in ohm ( $\Omega$ ) increases in proportion to the temperature (100  $\Omega$  at 0°C).

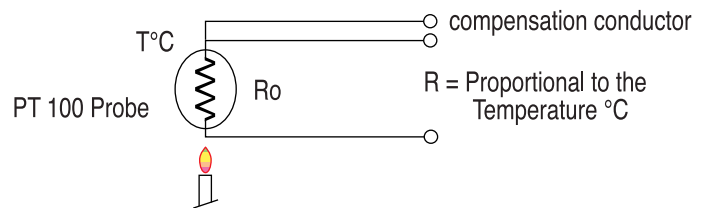

The resistance measurement is carried out by the current circulation generated by a measuring device or a regulator, through copper interconnecting wires.

The compensation for the interconnection conductor resistance is obtained by an artifice which consists in connecting a third wire (industrial applications) or even a fourth wire (laboratory applications).

The colours of the wires (white and red), the resistance variation and the precision class are defined in EN 60751 standard:

**Class A (1/2 class B) : +/- (0.15°C + 0.0025.t)**

**Class B : +/- (0.3°C + 0.005.t)**

**1/10 class B : (0.03°C + 0.0005.t)**

t = temperature measured in °C.

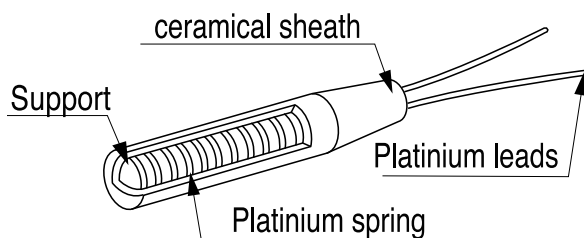

The sensitive element is inserted into a rigid sheath having a minimum diameter of **3 mm** and a minimum length of **30 mm**, and then extended by wires, a flexible cable or a cable with a mineral insulator.

The customary diameters of the rigid sheaths for probes are 4, 5, 6 and 8 mm. The customary diameters of deformable probes consisting of cables with mineral insulators are 3, 4, 5 and 6 mm.

Metallic protection sheaths are generally of AISI 316L/ DIN 1.4404 stainless steel when immersed in a fluid and AISI 304 L / DIN 1.4306 stainless steel when inserted into a thermometer well.

The response time of a probe depends on its diameter (approximately 4 sec in water for 3 mm diameter and 11 sec for 8 mm diameter).

The interconnection cables (one white conductor and two red conductors) provide a way of connecting the probes to a measuring or regulating device. Considering the low level of the transmitted signal, it is preferable to use shielded cables.

## THERMOCOUPLE

A thermocouple is a soldered joint between 2 wires of different metals (known as "hot soldering") across the terminals of which an electrical voltage is generated proportional to the measured temperature.

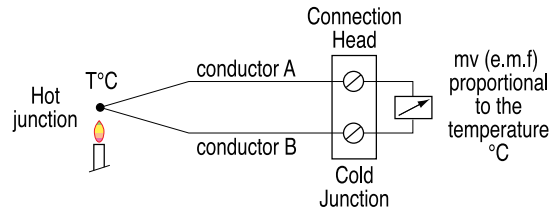

Analysis of this signal must be carried out by instrumentation and suitable interconnection wires compensating for the errors caused by the nature and temperature of the different connecting parts. For each type of thermocouple, the metal forming the conductors, the colour of the wires, the electromotive force and the precision class are defined by standards EN 60584-1 and EN 60584-2, of which the main types are:

Code	Nominal scale	Polarity	Colour	Precision	
				Class 1	Class 2
<b>J</b>	-40°C to +750°C	Fe +	<b>Black</b>	± 1,5°C	± 2,5°C
		Cst -	<b>White</b>	or ± -0,004.t	or ± -0,0075.t °C
<b>K</b>	-40°C to +1200°C	NiCr +--	<b>Green</b>	± 1,5°C	± 2,5°C
		NiAl --	<b>White</b>	or ± 0,004.t	or ± 0,0075.t °C
<b>N</b>	-40°C to +1200°C	NiCr +--	<b>Pink</b>	± 1,5°C	± 1,5°C
		Nis --	<b>White</b>	or ± 0,004.t	or ± 0,0075.t °C
<b>R</b>	0°C to 1600°C	Pt +	<b>Orange</b>	± 1°C	± 1,5°C
		PtRh13	<b>White</b>	or ± 0,0015.t	or ± 0,0025.t °C
<b>S</b>	0°C to 1600°C	Pt +	<b>Orange</b>	± 1°C	± 1,5°C
		PtRh10 +	<b>White</b>	or ± 0,0015.t	± 0,0025.t °C
<b>T</b>	-40°C to 350°C	Cu +	<b>Brown</b>	± 0,5°C	± 1°C
		Cst -	<b>White</b>	or ± 0,004.t°C	± 0,0075.t °C

There are several thermocouple technologies:

- Bare wires, if necessary protected by insulating beads and inserted into a rigid tube with customary diameters of: 3 or 4 or 5 or 6 mm.
- Mineral insulated cables are defined by standard EN 61515 with customary diameters of: 0.5 , 1, 2, 3, 4.5, 6 or 8 mm.

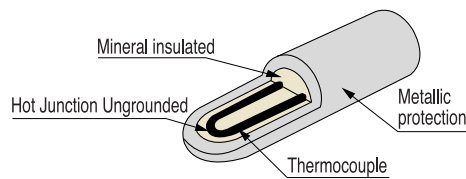

When the installation is by the measuring device or the regulator, the hot soldered joint can be connected to ground to reduce the sensor response time.

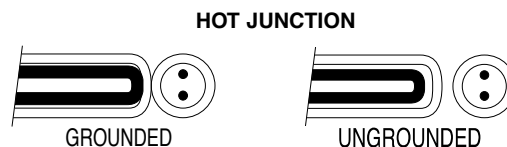

Metallic protection sheaths are generally of AISI 316L/ Din 1.4404 stainless steel for type J and of Inconel 600 for type K (when immersed in a fluid) or AISI 304 L/ Din 1.4306 stainless steel (when inserted into a thermometer well). The response time of a thermocouple depends on its diameter (approximately 0.05 sec in water for 0.5 mm diameter and 5 sec for 8 mm diameter). Divide these values by two when the hot soldered joint is connected to ground. The extension cables (conductors of the same type as those of the couple) or compensation cables (conductors of different types from those of the couple) are governed by standard IEC 584-3. They are indispensable for connecting thermocouples to a measuring or regulating device. Considering the low level of the transmitted signal (a few mV), it is preferable to use shielded cables. Compensated connectors are necessary for the connection of these cables.

### PT100 SENSORS WITH PVC CABLE

PT 100 ohm at 0°C class B sensing element, inside a 316L stainless steel sheath, with sealed end and 3 wire PVC insulated cable with connection thimbles, with or without shielding.

Temperature range : - 30 to + 90°C.

Other manufacturing capabilities : accuracy from class A up to 1/10 class B ,diameter 5 or 6 mm, total sheath length from 50 up to 1000 mm, other cable length, other types of electrical connections, 4 wires circuit.

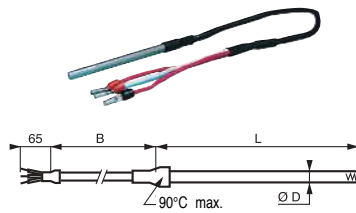

P/N.	Ø D (mm)	braided sheath	L (mm)	B (mm)	Weight (kg)
31030-09	5	without	50	5000	0,04
31030-10	5	without	100	5000	0,08
31030-11	5	without	150	5000	0,12
31030-12	6	with	50	5000	0,04
31030-13	6	with	100	5000	0,08
31030-02	6	with	150	5000	0,12
31030-04	6	with	250	5000	0,18
31030-05	6	with	300	5000	0,24
31030-06	6	with	550	5000	0,321

### PT100 SENSORS WITH FEP SHIELDED CABLE

PT 100 ohm at 0°C class B sensing element, inside a AISI 316L/ Din 1.4404 stainless steel sheath, with sealed end and 3 wires FEP insulated cable with connection thimbles and shielding.

Temperature range : - 60 to + 200°C.

Other manufacturing capabilities : accuracy from class A up to 1/10 class B ,diameter 5 or 6 mm total sheath length from 50 up to 1000 mm, other cable length, other types of electrical connections, 4 wires circuit.

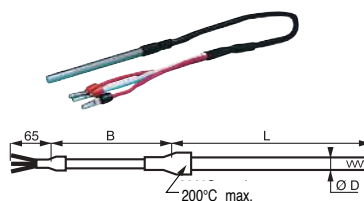

P/N.	Ø D (mm)	L (mm)	B (mm)	Weight (kg)
31035-11	6	30	5000	0,03
31035-14	6	50	5000	0,04
31035-15	6	100	5000	0,1
31035-12	6	150	5000	0,15
31035-13	6	300	5000	0,28

### FLEXIBLE MINERAL INSULATED PT100 SENSORS WITH PVC SHIELDED CABLE

PT 100 ohm at 0°C class B sensing element, inside a 316L flexible stainless steel sheath, with sealed end and 3 wires PVC insulated cable with connection thimbles and shielding. A coiled spring protects the lead wires against sharp bends in the transition area.

Temperature range : - 50 to + 500°C (element).  
- 30 to + 90°C (cable)

Other manufacturing capabilities : accuracy from class A up to 1/10 class B ,diameter 4,5 or 6 mm, total sheath length from 100 up to 5000 mm, other cable length, other types of electrical connections, 4 wires circuit, adjustable compression fitting type 31271.

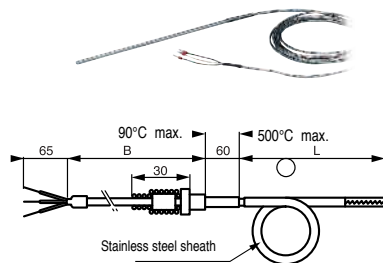

P/N.	Ø D (mm)	L (mm)	B (mm)	Weight (kg)
31048-01	4,5	150	5000	0,13
31048-02	4,5	250	5000	0,17
31048-03	4,5	350	5000	0,27
31048-04	4,5	500	5000	0,34
31048-05	4,5	1000	5000	0,61

### PT100 SENSORS WITH HIGH TEMPERATURE CABLE

PT 100 ohm at 0°C class B sensing element, inside a AISI 316L/Din 4404 no flexible stainless steel sheath, with sealed end and 3 wires fibreglass insulated cable (350°C maxi) with connection thimbles and metallic overbraid. A coiled spring protects the lead wires against sharp bends in the transition area.

Temperature range : - 50 to +500°C .

Other manufacturing capabilities : accuracy from class A up to 1/10 class B, diameter 4,5 or 6 mm, total sheath length from 100 up to 5000 mm, other cable length, other types of electrical connections, 4 wire circuit, adjustable compression fitting type 31271.

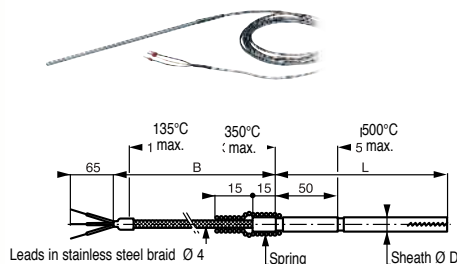

P/N.	Ø D (mm)	L (mm)	B (mm)	Weight (kg)
31032-03	4,5	100	2500	0,09
31032-01	4,5	200	2500	0,15
31032-04	4,5	300	2500	0,26
31032-05	6	150	2500	0,10
31032-02	6	250	2500	0,18
31032-06	6	300	2500	0,20
31032-07	6	550	2500	0,35



## PT100 SENSORS WITH IP66 HEAD

PT 100 ohm at 0°C class B sensing element, inside a AISI 316L/Din 1.4404 stainless steel sheath - Ø 9 mm thickness 1 mm.

Temperature range : - 50 to + 500°C (sensor).

Threaded fitting below the head (DAN-V) in Epoxy coated alloy, hinged cover fixed by screws (IP66) .Sealing gland for leads (8mm) is provided

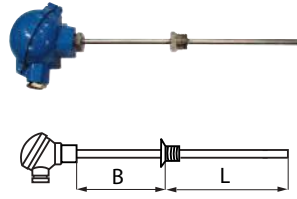

P/N.	Ø D (mm)	B (mm)	L (mm)	Weigh (kg)
31117-01	3/8"BSPT	0	100	0,1
31117-02	1/2"BSPP	0	100	0,1
31117-03	1/2"BSPP	0	250	0,2
31117-04	1/2"BSPP	145	100	0,2
31117-05	1/2"BSPP	145	250	0,3
31117-06	3/8"BSPT	145	100	0,1

## PT100 SENSORS WITH IP54 HEAD AND FLANGE FITTING

PT 100 ohm at 0°C class B sensing element, inside a AISI 316L/Din 1.4404 stainless steel sheath - Ø 6 mm the lectrical connection is done by a 3 poles terminal block inside an IP54 aluminium head, epoxy painted.

Temperature range : - 50 to + 500°C (sensor).

Fitting by Flange stainless steel sliding.



P/N.	Ø D (mm)	L (mm)	Weigh (kg)
31118-01	6	250	0,1
31118-02	6	500	0,15

## PT100 SENSORS WITH MINIATURE IP54 ALUMINIUM HEAD

PT 100 ohm at 0°C class B sensing element, inside a AISI 316L/Din 1.4404 stainless steel sheath. Electrical connection by a 3 poles terminal block inside an IP54 miniature aluminium head, epoxy painted, with compression gland ISO 16. Supplied with or without a 1/2" BSPT threaded fitting, welded below the head.

Temperature range : - 50 to + 500°C (sensor)  
- 50 to + 80°C (box)

Other manufacturing capabilities : accuracy from class A up to 1/10 class B ,diameter 5 or 6 mm, total sheath length from 50 up to 1000 mm, 4 wires circuit, fastening by sliding flange.

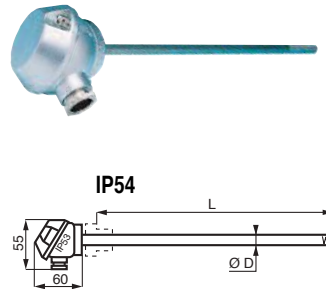

P/N.	Ø D (mm)	L (mm)	Connector	Weight (kg)
31042-08	6	100	without	0,1
31042-01	6	100	with	0,16
31042-04	6	150	without	0,11
31042-09	6	150	with	0,2
31042-02	6	200	without	0,13
31042-10	6	200	with	0,24
31042-05	6	250	without	0,16

## FLEXIBLE MINERAL INSULATED PT100 SENSORS WITH IP65 ALUMINIUM HEAD

Single PT sensor, 100 ohm at 0°C, class B, in a flexible stainless steel sheath with sealed end and 3 terminals in a miniature box (80°C max.) with a ISO 16 gland.

Temperature range : - 50 to + 500°C (element)  
- 10 to + 80°C (head)

Other manufacturing capabilities : accuracy from class A up to 1/10 class B ,diameter 4,5 or 6 mm, total sheath length from 100 up to 5000 mm, 4 wires circuit, fastening by compression fitting type 31271. or mounting flange.

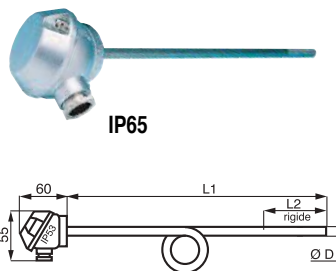

P/N.	D (mm)	L1 (mm)	L2 (mm)	Weight (kg)
31023-07	4,5	100	30	0,08
31023-08	4,5	200	30	0,12
31023-09	4,5	300	30	0,17
31023-10	6	300	30	0,25
31023-11	6	400	30	0,30
31023-12	6	500	30	0,35

## FLEXIBLE MINERAL INSULATED PT100 SENSORS WITH IP65 ALUMINIUM HEAD

PT 100 ohm at 0°C class B sensing element, inside a AISI 316L/ Din 1.4404 flexible stainless steel sheath. Electrical connection by a 3 poles terminal block inside an IP 65 aluminium head, epoxy painted, with compression gland for cable dia 4 to 15 mm.

Temperature range : - 50 to + 500°C (element)  
- 10 to + 80°C (head)

Other manufacturing capabilities : accuracy from class A up to 1/10 class B ,diameter 4,5 or 6 mm, total sheath length from 100 up to 5000 mm, 4 wires circuit, fastening by compression fitting type 31721, 4/20 mA transmitter installed inside the head.

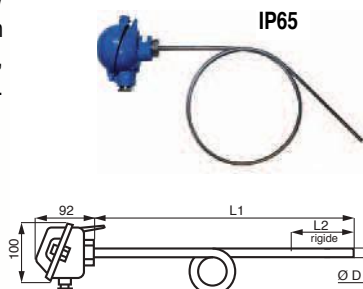

P/N.	Ø D (mm)	L1 (mm)	L2 (mm)	Weight (kg)
31022-01	4,5	150	30	0,12
31022-02	4,5	200	30	0,16
31022-03	4,5	300	30	0,24
31022-04	4,5	350	30	0,30
31022-05	4,5	500	30	0,34
31022-06	4,5	550	30	0,36

**PT 100 SENSORS WITH IP65 OFFSET ALUMINIUM HEAD**

PT 100 ohm at 0°C class B sensing element, inside a AISI 304L /Din 1.4306 stainless steel sheath. Electrical connection by a 3 poles terminal block inside an IP 65 offset aluminium head, epoxy painted, with compression gland for cable dia 4 to 15 mm. Spring loaded terminals, with a 8 mm clearance (the L dimension is corresponding to the half compression of the spring) Offset AISI316 L /Din 1.4404 nipple 1/2" NPT threaded fitting

Temperature range : - 50 to + 500°C (element)  
- 50 to + 80°C (head)

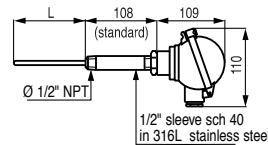

P/N.	Ø D (mm)	L1 (mm)
31045-01	4,5	100
31045-02	4,5	200
31045-03	4,5	300
31045-04	6	100
31045-05	6	200
31045-06	6	300

Other manufacturing capabilities : accuracy from class A up to 1/10 class B, total sheath length from 50 up to 1000 mm, offset nipple length 58 or 108 mm, 4 wires circuit, possible fixing nipple union, ATEX approval Ex ia or Ex e, 4/20 mA transmitter installed inside the head.

**FLEXIBLE PT 100 SENSORS WITH IP65 STAINLESS STEEL HEAD**

PT 100 ohm at 0°C class B sensing element, inside a flexible AISI 316L/Din 1.4404 stainless steel sheath. Electrical connection by a 3 poles terminal block inside an IP 65 stainless steel AISI 316L/Din 1.4404 head, epoxy painted, with compression gland for cable dia 4 up to 15 mm.

1/2" NPT threaded fitting welded below the head  
Temperature range : - 50 to + 500°C (element)  
- 50 to + 80°C (head)

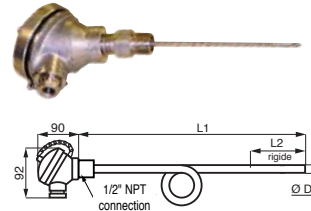

P/N.	Ø D (mm)	L1 (mm)
31043-10	6	100
31043-11	6	200
31043-12	6	300
31043-13	6	400

Other manufacturing capabilities : accuracy from class A up to 1/10 class B , diameter 6 mm, total sheath length from 100 up to 5000 mm, 4 wire circuits, 4/20 mA transmitter installed inside the head.

**FLEXIBLE PT 100 SENSORS WITH ATEX HEAD - Ex d - IP65**

PT 100 ohm at 0°C class B sensing element, inside a flexible AISI 316L/Din1.4404 stainless steel sheath. Electrical connection by a 3 poles terminal block inside an IP 65 EXPLOSION PROOF head with a compression gland for cable dia 8 mm.

1/2" NPT threaded fitting welded below the head.  
temperature range: - 50 to + 500°C (element)  
- 20 to + 80°C (head)

Usable in hazardous areas (ambient temperature from -20 °C up to 80°C, relative humidity 95 % maximum).

Certificate: **LCIE 02 ATEX 6097X** some precautions must be taken for using this device. Consult us or read the instruction manual

Other manufacturing capabilities : accuracy from class A up to 1/10 class B, diameter 6 mm, total sheath length from 100 up to 1000 mm, 4 wire circuits, 4/20 mA transmitter installed inside the head.

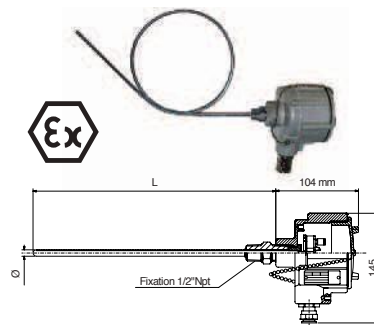

P/N.	Ø D (mm)	L1 (mm)
31043-15	6	100
31043-16	6	150
31043-17	6	200
31043-18	6	250
31043-19	6	300
31043-20	6	400

**PT 100 SENSORS WITH ATEX HEAD - Ex d - IP65**

PT 100 ohm at 0°C class B sensing element, inside a AISI 304L/ Din 1.4306 stainless steel sheath. Electrical connection by a 3 poles terminal block inside an IP 65 offset EXPLOSION PROOF head with compression gland for cable dia 8 mm. Spring loaded terminals, with a 8 mm clearance (the L dimension is corresponding to the half compression of the spring) Offset AISI316 L/Din 1.4406 nipple 1/2" NPT threaded fitting

Temperature range : - 50 to + 500°C (element)  
- 20 to + 80°C (head)

Usable in hazardous areas (ambient temperature from -20 °C up to 80°C, relative humidity 95 % maximum).

Certificate: **LCIE 02 ATEX 6097X** some precautions must be taken for using this device. Consult us or read the instruction manual

Other manufacturing capabilities : accuracy from class A up to 1/10 class B, total sheath length from 50 up to 1000 mm, offset nipple of 58 or 108 mm, 4 wires circuit, fastening nipple union, 4/20 mA.

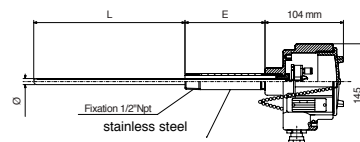

P/N.	Ø D (mm)	L1 (mm)	L2 (mm)
31045-07	4,5	100	108
31045-08	4,5	200	108
31045-09	4,5	300	108
31045-10	6	100	108
31045-11	6	200	108
31045-12	6	300	108

Options : transmitter installed inside the head.

## FLEXIBLE PT 100 SENSORS WITH ATEX HEAD - Ex d - IP65

PT 100 ohm at 0°C class B sensing element, inside a flexible AISI 316L/ Din 1.4404 stainless steel sheath. Electrical connection by a 3 poles terminal block inside a miniature EXPLOSION PROOF head IP 65 marking II 2 G Ex d IIC T6, with compression gland for cable dia 6 up to 9 mm. :  
 Temperature range : -50 to + 500°C (element)  
 - 20 to + 80°C (head)



Other manufacturing capabilities : accuracy from class A up to 1/10 class B diameter 4,5 or 6 mm, total sheath length from 100 up to 5000 mm, 4 wires circuit, fastening by compression fitting type 31721.

P/N.	Ø D (mm)	L (mm)
31026-01	4,5	200
31026-06	4,5	300
31026-07	6	300
31026-08	6	400

Usable in hazardous areas (ambient temperature from -20 °C up to 80°C, relative humidity 95 % maximum).  
 Certificate: **LCIE 02 ATEX 6097X** some precautions must be taken for using this device. Consult us or read the instruction manual

## PT 100 SENSORS WITH PTFE SHEATH AND FEP LEADS

PT 100 ohm at 0°C class B sensing element, inside a PTFE sheath, with sealed end and 3 wires FEP insulated leads with connection thimbles. Supplied with 3 terminals for electrical connection on 2,5 mm<sup>2</sup> wires.  
 Special design to be used with PTFE heating panel (see immersion heaters section).



P/N.	Max. temp.	Weight (kg)
26216-01	105°C	0,10

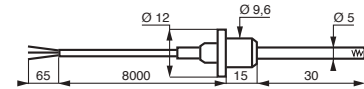

## PT 100 SENSORS FOR SKIN TEMPERATURE MEASUREMENT

PT 100 ohm at 0°C class B sensing element, inside a AISI 316L/Din 1.4404 stainless steel sheath, flattened to measure the skin temperature of hoses, with sealed end and 3 wires PFE insulated cable with connection thimbles and shielding.



P/N.	Max. temp.	B (mm)	Weight (kg)
31180-01	200°C	1000	0,2
31180-02	200°C	3000	0,4
31180-03	200°C	5000	0,7

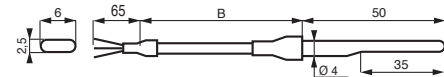

## RING LUG PROBES

Mainly intended for the measure of surfaces temperature on machine contact or thermic dissipators. Sensing element mounted in a terminal ring lug connector  
 Insulated conductors teflon/teflon cable length 1m.  
 2 Cables for TC or 3 conductive isolated wires for RTD 100



REF.	Probet	Ø D (mm)	Rqnge (°C)
31711-05	PT100 sensor	10,2	-50/+200
31711-02	Thermocouple K	5	-50/+280

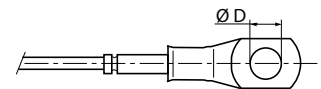

On request :  
 Others fixing diameter  
 Available for Atex areas (dust or gas)

## SCREW PLUG PT100 SENSORS

Compact probe for direct screwing in the part to measure.  
 PT 100 ohm at 0°C class B sensing element inside a AISI 316 L/Din 1.4404 screw. 3 wires PTFE insulated cable with connection thimbles.  
 Temperature range : - 80 to + 200°C



P/N.	Ø D	Length threaded (mm)
31109-01	1/4"-20 UNF	11
31109-02	M8 ISO	16
31109-03	M10 ISO	16

## ROOM AND OUTSIDE AMBIENT AIR TEMPERATURE PT 100 SENSORS

Room sensor : **P/N. 31055-01**  
 PT 100 ohm at 0°C class B sensing element inside a holed plastic box to IP 20, for wall mounting.  
 Temperature range : - 40 to + 85°C  
 Electrical connection by a 2, 3 or 4 poles terminal block through the bulkhead.

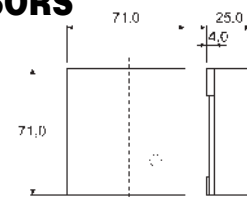

Outside ambient sensor : **P/N. 31055-02**  
 PT 100 ohm at 0°C class B sensing element inside a plastic box to IP 65, for wall mounting.  
 Temperature range : - 50 to + 100°C  
 Electrical connection by a 2, 3 or 4 poles terminal bloc, with compression gland..

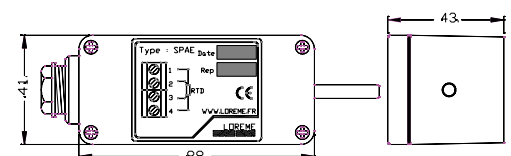



### LAMINAR PLATINUM PROBES 7,6 MMX7,6 MM

Sensing element Pt 100 Ω, Class B.  
 AWG 28 wire outputs Teflon lined  
 One adhesive side for attachment.  
 Thickness : 0,5 mm on element - 0,7 mm on wires.  
 Options on request :  
 • Without adhesive (-200°C / +200°C).  
 • Wire length > 1000 mm.

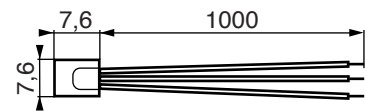

P/N.	Sensor	Accuracy.	Nr of wires	Isolator	Time constant	Temperature range
31132-51 •	Pt 100 Ω to 0°C	±0,12 Ω	3	Polymide insulated + Alu face	0,15 s	-20/+177°C*
31132-52 •	Pt 100 Ω to 0°C	±0,12 Ω	4	Polymide insulated + Alu face	0,15 s	-20/+177°C*
31132-53 •	Pt 100 Ω to 0°C	±0,12 Ω	2	Polymide insulated + Alu face	0,15 s	-20/+177°C*

\* For assembly without adhesive, operating temperature range : -200°C/+200°C

### LAMINAR PLATINUM PROBES 5 MM X 15 MM

Sensing element Pt 100 Ω or Pt 1000Ω  
 AWG 26 wire outputs Teflon lined  
 One adhesive side for attachment.  
 Thickness : 2 mm  
 Options on request :  
 • Without adhesive (-50°C / +200°C).  
 • Wire length > 1000 mm.

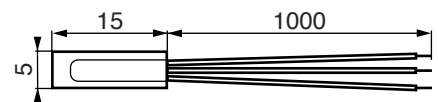

P/N.	Sensor	Accuracy.	Nr of wires	Isolator	Time constant	Temperature range
31132-01 •	Pt 100 Ω to 0°C	±0,12 Ω	3	Polymide insulated	1 s	-20/+177°C*
31132-02 •	Pt 100 Ω to 0°C	±0,12 Ω	4	Polymide insulated	1 s	-20/+177°C**

\* For assembly without adhesive, operating temperature : -50°C/+200°C

### MINIATURE FLANGED PLATINUM PROBES Ø 4,8 X 6,4 MM

Sensing element: PT 100 ohm at 0°C Class B  
 Vessel of tinned light alloy  
 Output by insulated wire with PTFE length 900 mm  
 These probes can be used whenever space is at a premium.  
 Other possibilities on request  
 Wire outputs without shielding braid  
 Copper probes 100 ohm  
 Nickel probes 120 ohm  
 Miniature sensors equipped with an antifriction end.  
 In this case, the load temperatures become:  
 Resistance probe: -50/+260°C  
 Wire outputs: without shielding braid  
 Wire length >900 mm

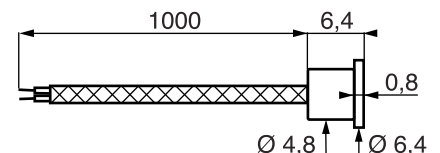

P/N.	Captor	Accuracy.	Probe	Temperature range	Nr lead	Section of lead mm <sup>2</sup>	Time constant
31123-04 •	Platinum 100 Ω to 0°C	±0,12 Ω	Simple	-50/+150°C	1 x 3	0,227	4 s
31123-09 •	Platinum 100 Ω to 0°C	±0,12 Ω	Double	-50/+150°C	2 x 3	0,089	4 s

Recommended installation:  
 Use spring P/N 31123-99 and clip P/N 31123-98 or P/N 31123-97 to retain the miniature flanged probe in its hole

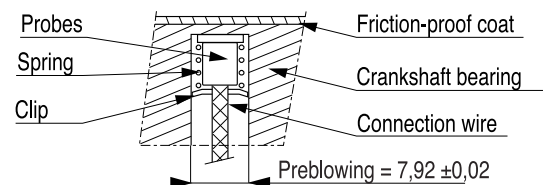

### FASTENING ACCESSORIES

Spring P/N 31123-99  
 - Stainless steel  
 - Compressed length: 5.6 mm

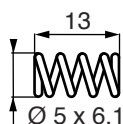

Clip P/N: 31123-98 for single or double sensors with Teflon wire  
 - Anticorrosion-treated carbon steel  
 - To be used for drilling diameter: 7.92 + 0.2 mm



Clip P/N: 31123-97 for single or double sensors with Teflon wires + shielding braid  
 - Anticorrosion treated carbon steel  
 - To be used on drilling diameter: 7.92 + 0.2 mm



## THERMOCOUPLES WITH HIGH TEMPERATURE EXTENSION CABLE

Class 2 thermocouples with ungrounded hot junctions, inside 316 L stainless steel sheath, with sealed end and 2 wires high temperature cable with metallic overbraid and connection thimbles  
Maximum operation temperature : 350°C.

Other manufacturing capabilities : accuracy class 1, total sheath length from 50 up to 1000 mm, other cable length, bended sensor, possible fixing by compression fitting or mounting flange, other thermocouple type R, S, T...

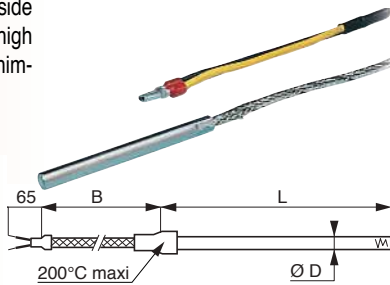

P/N. J type	P/N. K type	Ø D (mm)	L (mm)	B (mm)	Weight (kg)
31066-01	31066-11	4,5	50	2500	0,05
31066-03	31066-13	4,5	100	2500	0,1
31066-04	31066-14	4,5	200	2500	0,2
31066-05	31066-15	4,5	300	2500	0,3
31066-02	31066-12	6	150	2500	0,07
31066-06	31066-16	6	250	2500	0,12
31066-07	31066-17	6	550	2500	0,25

Other L or B lengths to order

## FLEXIBLE MINERAL INSULATED THERMOCOUPLES WITH PVC EXTENSION CABLE

Class 2 thermocouples with ungrounded hot junctions, inside flexible mineral insulated 316L stainless steel sheath, with sealed end and 2 wires PVC insulated cable (90°C maxi) and connection thimbles

Other manufacturing capabilities : accuracy class 1, diameter 0,5 or 1 or 2 or 3 or 4,5 or 6 or 8 mm, total flexible sheath length from 100 up to 5000 mm, other cable length, adjustable compression fitting type 31271, other thermocouple types R, S, T..., ATEX approval EEx ia.

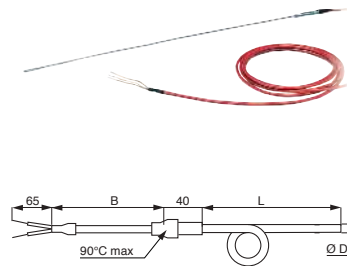

P/N.	T/C type	Ø D (mm)	Max. temp.	B (mm)	L (mm)	Weight (kg)
31061-01	K	3	1100°C	2500	500	0,07
31061-02	K	3	1100°C	2500	1000	0,1
31061-09	J	1	750°C	2500	500	0,05
31061-10	J	1	750°C	2500	1000	0,09
31061-12	J	2	750°C	2500	500	0,05
31061-11	J	2	750°C	2500	1000	0,1
31061-19	K	1	750°C	2500	500	0,05
31061-20	K	1	750°C	2500	1000	0,09
31061-22	K	2	750°C	2500	500	0,05
31061-21	K	2	750°C	2500	1000	0,1

## FLEXIBLE MINERAL INSULATED THERMOCOUPLES WITH HIGH TEMPERATURE EXTENSION CABLE

Class 2 thermocouples with ungrounded hot junctions inside flexible mineral insulated 316L (Type J) or Inconel 600 (Type K) stainless steel sheath, with sealed end and high temperature extension cable with metallic overbraid.  
Max. temperature: 600°C (J type) and 1000°C (K type).  
Max. cable temperature: 200°C. Fastening: use a type 31271 compression fitting.

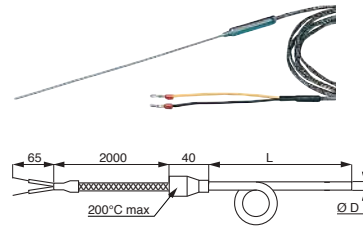

P/N.TCJ	P/N.TCK	ØD (mm)	L (mm)
31080-02	31214-02	0,5	150
31080-11	31214-11	1	200
31080-12	31214-12	1	250
31080-18	31214-18	1,5	150
31080-20	31214-20	1,5	250
31080-23	31214-23	2	200
31080-24	31214-24	2	250
31080-31	31214-31	3	200
31080-32	31214-32	3	250

Other manufacturing capabilities : accuracy class 1, diameter 0,5 or 1 or 2 or 3 or 4,5 or 6 or 8 mm, total flexible sheath length from 100 up to 5000 mm, other cable length, adjustable compression fitting type 31271.. R S T thermocouple type EExia, other thermocouple types R, S, T..., ATEX approval EEx ia.

## FLEXIBLE MINERAL INSULATED THERMOCOUPLES WITH CONNECTOR AND PVC EXTENSION CABLE

Class 2 thermocouples with ungrounded hot junctions inside flexible mineral insulated 316L (Type J) or Inconel 600 (Type K) stainless steel sheath, with an electrical plug, and with an optional shielded PVC extension cable.  
Maximum operation temperature : 600°C (TC J) or 1000°C (TCK), 200°C on the connector and 90°C on the cable.

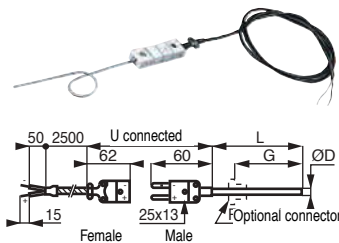

P/N.TCJ	P/N.TCK	ØD (mm)	A (mm)	U (mm)	Optional connector	Weight (kg)
31064-01	31064-11	3	500	106	with	0,09
31064-02	31064-12	3	1000	106	with	0,11
31064-03	31064-13	3	1500	106	with	0,13
31064-04	31064-08	3	100	0	without	0,09
31064-05	31064-09	3	200	0	without	0,09
31064-06	31064-10	3	300	0	without	0,09
31064-07	31064-14	3	400	0	without	0,10
31064-19	31064-15	6	100	0	without	0,09
31064-20	31064-16	6	200	0	without	0,09
31064-23	31064-17	6	300	0	without	0,10
31064-25	31064-18	6	400	0	without	0,10

A = "L" if there is no connector.  
A = "G" if there is connector.

## THERMOCOUPLES WITH IP65 OFFSET ALUMINIUM HEAD

Class 2 thermocouples with ungrounded hot junctions inside 304L (Type J) or Inconel 600 (Type K) stainless steel sheath. Electrical connection by 2 poles terminal blocks inside an IP 65 offset aluminium head, epoxy painted, with compression gland for cable dia 4 to 15 mm. Spring loaded terminals, with a 8 mm clearance (the L1 dimension is corresponding to the half compression of the spring) Offset 316 L nipple 1/2" NPT threaded fitting  
Max operating temperature : 600°C (TC J) or 1000°C (TCK), and 80°C on the head

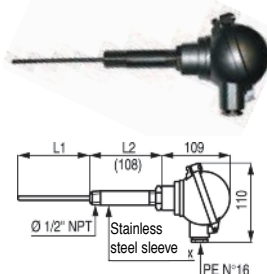

P/N. J type	P/N. K type	Ø D (mm)	L1 (mm)	L2 (mm)
31075-01	31075-05	3	100	108
31075-02	31075-06	3	150	108
31075-03	31075-07	3	200	108
31075-04	31075-08	3	250	108
	31075-09	6	100	108
	31075-10	6	150	108
	31075-11	6	200	108
	31075-12	6	250	108

**FLEXIBLE MINERAL INSULATED THERMOCOUPLES - Ex d - IP65**

Class 2 thermocouples with ungrounded hot junctions inside flexible mineral insulated 316L (Type J) or Inconel 600 (Type K) stainless steel sheath. Electrical connection by 2 poles terminal blocks inside an IP65 EXPLOSION PROOF head Marking : II 2 G Ex d IIC T6 with a compression gland for cable dia 8 mm. 1/2" NPT threaded fitting welded below the head  
Maximum operating temperature : 600°C (TC J) or 1000°C (TC K),  
Temperature range : - 20 to + 80°C on the head  
Other manufacturing capabilities : accuracy class 1, diameter 3 or 4,5 or 6 or 8 mm, total flexible sheath length from 100 up to 1000 mm, other thermocouple types R,S,T..., 4/20 mA transmitter installed inside the head.

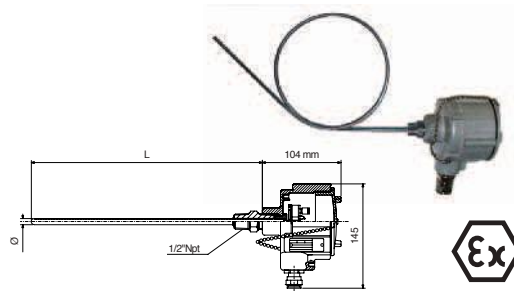

P/N. J type	P/N. K type	Ø D (mm)	L (mm)
31068-10	31068-13	3	100
31068-11	31068-14	3	150
31068-12	31068-15	3	200
	31068-16	6	100
	31068-17	6	150
	31068-18	6	200

Usable in hazardous areas (ambient temperature from -20 °C up to 80°C, relative humidity 95 % maximum). Certificate: **LCIE 02 ATEX 6097X** some precautions must be taken for using this device. Consult us or read the instruction manual

**THERMOCOUPLES WITH OFFSET - Ex d - IP65**

Class 2 thermocouples with ungrounded hot junctions inside 304L (Type J) or Inconel 600 (Type K) stainless steel sheath. Electrical connection by 2 poles terminal blocks inside an IP 65 EXPLOSION PROOF head Marking : II 2 G Ex d IIC T6 with a compression gland for cable dia 8 mm.  
Offset 316 L nipple 1/2" NPT threaded fitting  
Maximum operating temperature : 600°C (TCJ) or 1000°C (TCK),  
Temperature range : - 20 to + 80°C on the head  
Other manufacturing capabilities : accuracy class 1, diameter 3 or 4,5 or 6 or 8 mm, total flexible sheath length from 100 up to 1000 mm, other thermocouple types R,S,T..., 4/20 mA transmitter installed inside the head.

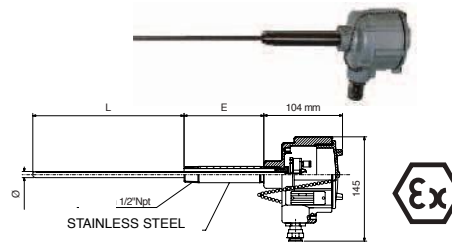

P/N. J type	P/N. K type	Ø D (mm)	L1 (mm)	L2 (mm)
31075-13	31075-17	3	100	108
31075-14	31075-18	3	150	108
31075-15	31075-19	3	200	108
31075-16	31075-20	3	250	108
	31075-21	6	100	108
	31075-22	6	150	108
	31075-23	6	200	108
	31075-24	6	250	108

Usable in hazardous areas (ambient temperature from -20 °C up to 80°C, relative humidity 95 % maximum). Certificate: **LCIE 02 ATEX 6097X** some precautions must be taken for using this device. Consult us or read the instruction manual

**THERMOCOUPLES WITH MINIATURE IP54 ALUMINIUM HEAD**

Class 2 thermocouples with ungrounded hot junctions inside 316L (Type J) or Inconel 600 (Type K) stainless steel sheath. Electrical connection by 2 pole terminal blocks inside an IP54 miniature aluminium head, epoxy painted, with compression gland N°9.  
Maximum operating temperature : 600°C (TC J) or 1000°C (TCK) and 80°C on the head.

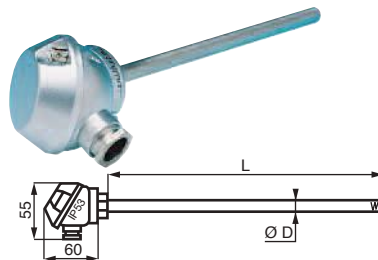

P/N. J type	P/N. K type	Ø D (mm)	L (mm)	Weight (kg)
31067-01	31067-03	8	150	0,13
31067-05	31067-13	8	250	0,15
31067-02	31067-04	8	300	0,17
31067-11	31067-14	8	350	0,19
31067-12	31067-15	8	550	0,31

**FLEXIBLE MINERAL INSULATED THERMOCOUPLES WITH IP65 ALUMINIUM HEAD**

Class 2 thermocouples with ungrounded hot junctions inside 316L (Type J) or Inconel 600 (Type K) stainless steel sheath. Electrical connection by 2 pole terminal blocks inside an IP 65 aluminium head, epoxy painted, with compression gland for cable dia 4 to 15 mm.  
Maximum operation temperature : 600°C (TC J) or 1000°C (TCK) and 80°C on the head  
Other manufacturing capabilities : accuracy class 1, diameter 3 or 4,5 or 6 or 8 mm, total flexible sheath length from 100 up to 5000 mm, adjustable compression fitting type 31271, other thermocouple types R, S, T. ATEX approval Ex ia. or Ex e, 4/20 mA transmitter installed inside the head.

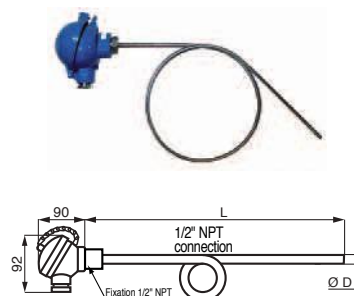

P/N. K type	Ø D (mm)	L (mm)	Weight (kg)
31068-61	4,5	150	0,06
31068-62	4,5	300	0,12
31068-63	4,5	550	0,2
31068-64	6	150	0,07
31068-65	6	200	0,09
31068-66	6	250	0,11
31068-67	6	300	0,14
31068-68	6	350	0,17
31068-69	6	550	0,26



## CLAMPING PROBES FOR SURFACE TEMPERATURE MEASUREMENT

These sensors are dedicated to the temperature measurement of pipes (eg : for heating systems). Protective sheath in stainless steel 316L, diameter 5 mm, end thinned for a best contact. 2 wires ( for TC) or 3 ( for PT100) insulated conductors teflon / teflon, 1 m length

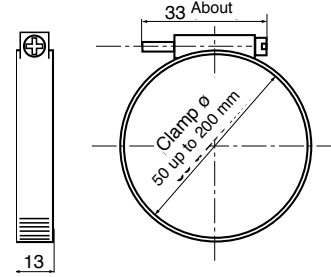

On request :  
Other clamping diameters up to 2 meters.  
Available in ATEX Gas and Dust.

REF.	Sensort	Range (°C)
31711-03	PT100 probe	-50/+200
31711-04	Thermocouple K	-50/+400

## ADJUSTABLE FASTENING FLANGES and FASTENING CLAMP

Flange for fastening 2 to 8 mm Ø probes to a duct wall or an insulating jacket. 3 fixing holes, Ø 5mm.

Clamp for fastening a 6 mm Ø probe to the flat wall of a low-pressure air duct. AISI 304L=Din 1.4306

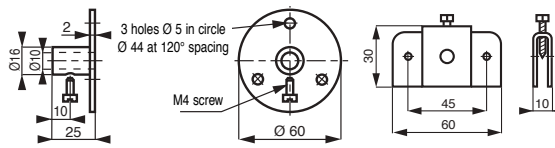

To be sealed after assembly with a heat-resistant silicone mastic.

P/N.	Article	Material
31979-01	Flange	Painted steel
31979-11	Flange	Stainless steel 304 L
31678-00	Clamp	Stainless steel 304 L

## EXTENSION CABLES FOR PLATINUM-PLATED PROBES

Flexible multicore cables for connecting PT probes to temperature controllers. Type 31455 is covered in metal braid. Supplied in 25`m rolls.

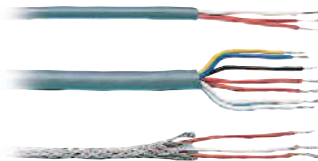

P/N.	Nrr. of wires	Section (mm <sup>2</sup> )	Max. ambient	Outside Ø (mm)	Insulator	Weight (kg)
31450-25	3	0,14	80°C	3	PVC	0,25
31452-25	3	0,22	80°C	4	PVC	0,5
31454-25	7	0,22	80°C	6	PVC	1,0
31455-25	3	0,22	220°C	3	GSV	0,4
31459-25	3	0,5	400°C	7,2	FIB/SIL	0,7

## STANDARD COMPENSATED PLUGS FOR THERMOCOUPLES

Allow a plugged connection between two thermocouple cables without measurement error, because their contacts are out of the same material as the sensor. The cable clamp fits the male and female plugs.



P/N.	T/C type	Description	Weight (kg)
31100-01	K	Standard male	0,020
31100-02	J	plug	0,020
31100-03	K	Standard female	0,015
31100-04	J	plug	0,015
31100-05	K	Standard female	0,015
31100-06	J	built-in plug	0,015
31100-07	K	Miniature male	0,005
31100-08	J	plug	0,005
31100-09	K	Miniature female	0,007
31100-10	J	plug	0,007
31100-11	K	Miniature female	0,005
31100-12	J	built-in plug	0,005
31100-13		Cable clamp for standard plug	0,010
31100-14		Cable clamp for miniature plug	0,008

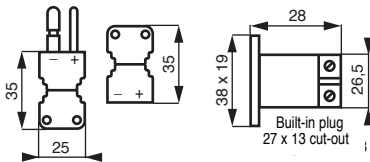

Standard plugs

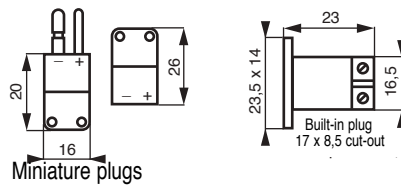

Miniature plugs

## 3-PIN PLUGS FOR PT 100 ohm/ 0°C PROBES

Allow a plugged connection between two three-core copper extension cables for 100 ohm/ 0°C platinum-plated probes. Max. operating temperature 175°C.



P/N.	Description	Colour	Weight (kg)
31101-01	Miniature male plug	White	0,009
31101-02	Miniature female plug	White	0,008
31101-03	Miniature female built-in plug	White	0,008
31101-04	Standard male plug	White	0,030
31101-05	Standard female plug	White	0,025
31101-06	Cable clamp for miniature plug		0,008
31101-07	Cable clamp for standard plug		0,010

## STAINLESS STEEL PROBE POCKETS, 3/8" AND 1/2" BSP

For easy dismantling of probes and thermocouples on liquid circulation heaters and pipe.

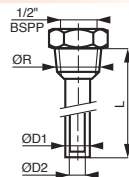

P/N.	Ø R	ØD1 (mm)	ØD2 (mm)	L (mm)	Material
31601-20	1/2" BSPT	13,5	8,9	100	304L/ 1.4306
31340-21	1/2" BSPT	13,5	8,9	200	304L/ 1.4306
31341-20	1/2" BSPT	9	7	100	304L/ 1.4306
31605-21	1/2" BSPT	9	7	200	304L/ 1.4306
31342-20	1/2" BSPT	9	7	300	304L/ 1.4306
31605-22	1/2" BSPT	9	7	500	304L/ 1.4306
31605-23	3/8" BSPT	9	7	200	304L/ 1.4306
31343-20	3/8" BSPT	13,5	8,9	150	304L/ 1.4306
31605-70	3/8" BSPT	9	7	150	304L/ 1.4306

P/N.	Ø R	ØD1 (mm)	ØD2 (mm)	L (mm)	Material
31390-21	1/2" BSPT	13,5	8,9	100	316L/1.4404
31391-21	1/2" BSPT	13,5	8,9	200	316L/1.4404
31392-20	1/2" BSPT	9	7	100	316L/1.4404
31393-20	1/2" BSPT	9	7	200	316L/1.4404
31394-20	1/2" BSPT	9	7	300	316L/1.4404
31395-20	1/2" BSPT	9	7	500	316L/1.4404
31396-20	3/8" BSPT	9	7	200	316L/1.4404
31396-70	3/8" BSPT	9	7	150	316L/1.4404
31397-20	3/8" BSPT	13,5	8,9	150	316L/1.4404

## BRASS PROBE POCKETS

These models are especially suited to three phases safety temperature thermostats, P/N. 9014-13.

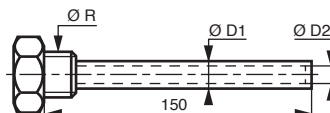

P/N.	Ø R	ØD1 (mm)	ØD2 (mm)	L (mm)	Material
9014-10	3/8" BSPP	9,5	8,5	150	Brass

Weight: 0,06 kg

## BICONE UNIONS

For sealed fixing of rigid or flexible probes by crimping on a sliding 3-piece union.

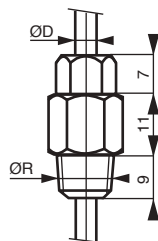

P/N.	Material	Ø D (mm)	Ø R
31664-00	316L / Din 1.4404	1	M 4 x 70
31656-00	brass	1	M 8 x 125
31446-00	316L / Din 1.4404	1,2	M 4 x 70
31447-00	brass	1,2	M 8 x 125
31665-00	316L / Din 1.4404	1,5	M 4 x 70
31657-00	brass	1,5	M 8 x 125
31666-00	316L / Din 1.4404	2	M 8 x 125
31658-00	brass	2	M 8 x 125
31448-00	316L / Din 1.4404	2,5	M 8 x 125
31449-00	brass	2,5	M 8 x 125
31667-00	316L / Din 1.4404	3	M 8 x 125

P/N.	Material	Ø D (mm)	Ø R
31659-00	brass	3	M 8 x 125
31659-01	316 L stainless steel	3,2	M 8 x 125
31668-00	316L / Din 1.4404	3,5	M 8 x 125
31660-00	brass	3,5	M 8 x 125
31669-00	316L / Din 1.4404	4,5	M 8 x 125
31661-67	steel	4,5	1/4" BSPP
31670-00	316L / Din 1.4404	6	1/4" BSPT
31671-00	316L / Din 1.4404	6	3/8" BSPT
31672-00	316L / Din 1.4404	6	1/2" BSPP
31662-67	steel	6	1/2" BSPP
31673-00	316L / Din 1.4404	8	1/2" BSPP
31663-67	steel	8	1/2" BSPP

## BAYONET CONNECTORS

MALE BAYONET FITTINGS, nickel-plated brass, 2 pins Ø 3 mm. For fixing probe types 31065 and 31083

LONG MALE BAYONET FITTINGS, nickel-plated brass. For fixing probe types 31065 and 31083

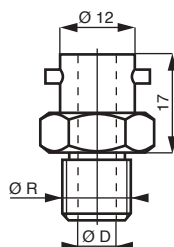

P/N.	Ø D (mm)	Ø R
31645-68	6,5	M 10 x 100
31871-68	6,5	M 10 x 150
31872-68	8,3	M 12 x 150
31873-68	8,3	M 12 x 175
31874-68	8,3	M 14 x 150
31875-68	8,3	M 14 x 200
31876-68	8,3	1/4" BSPP

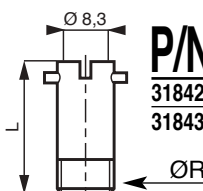

P/N.	L (mm)	Ø R
31842-68	35	M 12 x 100
31843-68	60	M 12 x 100

## THREADED WELD-ON BOSSES

For sealed fixing of rigid or flexible probes  
AISI 304L = Din 1.4306  
AISI 316L = Din 1.4404

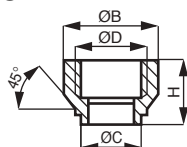

P/N.	P/N.	P/N.	ØB (mm)	ØC (mm)	ØD (mm)	H (mm)	Weight (kg)
31978-01	31978-11	31978-21	25,5	14	1/4" BSPP	30	0,085
31978-02	31978-12	31978-22	32	17,5	3/8" BSPP	30	0,113
31978-03	31978-13	31978-23	41	21,6	1/2" BSPP	33,5	0,141

## POWER SUPPLIES FOR CONVERTER P/N.30713-01

These power supplies are particularly suitable for the implementation of converters with 2 wires (loop powered 4-20 mA)..  
The isolation between each output eliminates ground loop problems that can disturb the measurement  
The coupling in serial or parallel increases the current or voltage output .

- Assembly : DIN rail unit .
- Outputs : from 1 up to 8, presetting voltage 24 Vdc, 30 mA (other voltages are available).
- Permanent protection against short circuits.
- Insulation voltage between 1500 to 3000 V.
- Green LED when the power is switch on.

Input: 230Vac +/- 10% (other voltages available from 11 to 265 V AC or DC).

Output: on request from 0 to 24V DC (power 1watt/sortie), higher voltage is possible with parallel outputs (maximum 8x24V).



## PROGRAMMABLE CONVERTERS FOR ROD HEAD P/N. 31712-00

31712-00 type are digital converters for a rod head using the 2-wire technique

**Input :** PT 100 ohm or thermocouple J K T R S B or mv

**Output :** 4/20 mA programmable for scale, response time and input type

Linearization, cold solder compensation and line resistance compensation incorporated into the converter.

Power supply between 9 and 40 Vdc with load resistance at 24 Vdc 750 ohm

Operating temperature range: -30 °C + 85 °C

Attaching centre distance 33 mm, 7 mm central role to accommodate sensor wires

Connection by screw-on terminal with 2.5 mm<sup>2</sup> capacity.

Indication of power supply presence by LED

Protection against polarity reversal

Protection from shock and vibration (silicone coating resin)



Other production : version with galvanic insulation, hart protocol

## PROGRAMMABLE FIELD CONVERTERS WITH LOCAL DISPLAY P/N.31713-00

31713-00 type are 4/20 mA programmable converters using the two-wire technique with a local display assembled in an IP 65 epoxy painted aluminum case

**Input :** thermocouple JKTRSB with PT 100 Ohm probe .

**Output :** 4/20 mA programmable for scale, response time and input type

LCD display of extended temperature (4 digits) Resolution 10 000 points

Linearization, cold solder compensation and line resistance compensation incorporated into the converter.

Power supply between 12 and 40 Vdc with load resistance at 24 Vdc 550 ohm.

Operating temperature range: -20 °C + 60 °C

Connection by screw-on terminal with 2.5 mm<sup>2</sup> capacity. Protection against polarity reversal

IP 65 epoxy painted aluminum case with electrical output by PG 16 g cable gland for 7/12 mm

Process assembly by 1/2" cylindrical gas threading



## MULTI GENERAL MEASUREMENT UNITS TYPE 31714

Assembly : - plug-in type, case 96 x 96 x 150 mm

Configurable inputs : - : 4,8,12 inputs, according to the P/N above (identical configuration for all the channels).

- Pt100 2 or 3 wires, linearised
- Compensated and linearised thermocouple
- mV, mA, ohm

Configurable alarms : - 2 configurable alarms for each channels

- detection of probe breakage and of measurement threshold

Relays : - 2 relays for all the channels

- inverter relay, potential free

Display : - 4 digits LCD 7 segments, 10 000 points

- display of measurement, fixed point, scrolling, alarm threshold adjustments

Power supply : - 230 Vac: other voltage to be defined on order

Insulation : - power supply/input/relay 1500 Vac

- input/output 250 Vac

Parameter settings : - RS232 link (cord not supplied, on request)



P/N.	Input nbr.
31714-04	4
31714-08	8
31714-12	12

**Application:** centralised supervision and monitoring of temperature

**Advantage:** compact, low cost.

## GENERAL-PURPOSE DIGITAL CONVERTERS P/N.31715-00

Assembly : - DIN rail unit: 23 x 100 x 120 mm

Configurable input : - Pt100, thermocouple  
- mV, V, mA, ohm  
- sensor power supply, potentiometer, stress gauge  
- frequency: TTL, Namur, NPN, PNP, .....

Special functions : - square root extraction

- customised linearisation

Configurable output : - 1 current output 0...4.... 20 mA, voltage 0 to 10 V

Second isolated output : - option (CNL 35L/S2)

Configurable relays (as an option) : - max 4 relays, potential free

- detection of probe breakage and of measurement threshold

Power supply : - 20 to 265 Vac-dc, or 9 to 30 Vdc on request

Insulation : - input/output 1500 Vac power supply

Parameter settings : - RS232 link or front panel



**Application:** measurement of industrial signals, temperature, speed, weight, position, flow rate, etc

**Advantage:** wide range of applications fully configurable by the user



## APPLICATIONS

- Power
- Testing
- Instrumentation
- Regulation

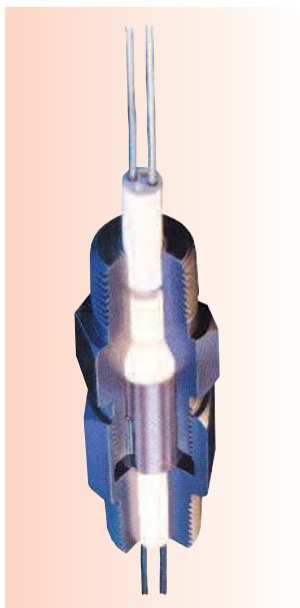

## USES

**-240°C to + 870°C**

Liquid



690 bar\*

Gas



690 bar\*



-5.10<sup>-6</sup> Hg

### 31270 TYPE

This type Glands seal a single tube or probe. Featuring a metal-to-metal seal rather than our standard soft sealing technology, glands are used where a joint must be opened and released in the same setting. Their unique design forms the seal well within the vessel housing to provide superior performance in high vibration applications.

Metal to metal tube and probe sealing.



Multiple sensors and probe glands



### 31272 TYPE

Glands enable multiple thermocouples, thermistor probes, RTD's, tubes or other sensors to pass through a single gland. Each probe is electrically isolated and its immersion length is adjustable. Elements may be individually adjusted, removed and replaced.

### 31273 TYPE

Can often be used when the other type of probe glands are not suitable - they can be customized to accommodate non-standard sizes and a mixture of element sizes, for special hole patterns and for a higher density of elements than can be accommodated by other types of sealing assemblies.

Multiple sensors and probe glands, for non-standard sizes and custom configurations - glands



Single and multiple sensor glands with split internal components



### 31171/31172 TYPE

These glands are used when the elements to be sealed can pass through the gland vessel but not through the internal components. Their process ends may be of a larger diameter than at the sealing points, there may be connectors to pass through the gland, elements may be long and difficult to handle, or, there are other installation constraints.

### 31275 TYPE

These power lead glands have kapton insulated copper wire in a number of wire sizes. They are used to feed through power leads to autoclaves and sterilisers, transformers, motors and heaters. Wires are individually marked at both ends and are easily installed or replaced.

Insulated wire sealing



Single electrode with ceramic insulators 31277 glands; and with Teflon insulator/sealing - 31278 glands

### 31277/31278 TYPE

These single conductor sealing glands are used for high voltage and/or high current feedthroughs to vacuum chambers, autoclaves, transformers, motor enclosures, reactor vessels and environmental chambers. Type 31277 are available with a choice of sealants and have ceramic insulators. Max.rating 2kV/400A. Type 31278 glands employ a single-piece, Teflon, combined insulator/sealant component to surround the electrode. Max.rating 8kV/525A..



High density, mechanically sealed, wire feedthroughs using single or multiple probe glands



### 31173 TYPE

These feedthrough assemblies comprise a high-density, wire feedthrough mounted in a sealing gland. A Teflon-lined, stainless steel tube is swaged over 12, 24, 40 or 60, solid, Teflon-coated, copper and/or thermocouple material wires to make the continuous wire feedthrough for thermocouples, RTD's and low voltage instrumentation.

- SEALS A SINGLE ELEMENT - USUALLY A TUBE, PROBE OR SENSOR
- FOR GAS OR LIQUID APPLICATIONS
- PRESSURE : Vacuum to 690 bar
- TEMPERATURE : -240°C to +870°C
- FIELD ADJUSTABLE
- REPLACEABLE SEALANT FOR REPEATED USE OF FITTING
- STAINLESS STEEL BODY, CAP AND FOLLOWER
- SIMPLE ASSEMBLY - INSERT ELEMENT, TORQUE CAP

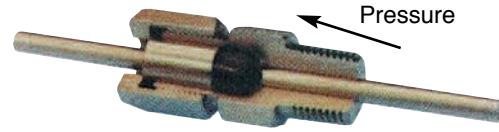

**TYPE 31271**

## SEALANT SELECTION GUIDE

31271 type glands are designed for sealing a single element, usually a tube or a probe, where it crosses a pressure or environmental boundary. Glands are available to carry elements.

Applications for glands include : Pressure and vacuum sealing of thermocouples, RTD's, dial-type thermometers, thermistor probes, glass thermometers, thermowells (pockets) including those made from fragile materials, capillary tubes and other sensor elements.

Sealant (sealant code)	Temperature range	Pressure range at 20°C
Neoprene (N)	-40°C to +93°C	Vacuum to 345 bar
Viton (V)	-20°C to +232°C	Vacuum to 690 bar
Teflon (T)	-185°C to + 232°C	Vacuum to 220 bar
Lava (L)	-185°C to +870°C	1bar to 690 bar
Grafoil (G)	-240°C to +495°C (to +1650°C in a reducing atmos.)	Vacuum to 690 bar

Diameter of element of seal thread**	Gland mounting thread	Pressure rating by Sealant*					L (mm)		Body Hex size (mm)
		Neoprene	Viton	Teflon	Lava	Grafoil	1 screw	2 screw	
		N	V	T	L	G			
0,5	1/16"	-	-	220	550	-	23,81	-	9
1	1/16"	-	-	220	550	-	23,81	-	9
1,5	1/16"	-	-	220	550	-	23,81	-	9
1	1/8"	165	220	275	385	-	30,2	39,7	13
1,5	1/8"	165	220	275	275	345	30,2	39,7	13
2	1/8"	165	165	220	275	345	30,2	39,7	13
2,5	1/8"	165	165	165	275	345	30,2	39,7	13
3	1/8"	165	165	165	275	345	30,2	39,7	13
3,5	1/8"	80	100	100	275	275	30,2	39,7	13
4	1/8"	80	100	100	275	275	30,2	39,7	13
4,5	1/8"	80	100	100	275	275	30,2	39,7	13
3	1/4"	345	690	220	690	690	50,8	60,4	19
3,5	1/4"	220	310	65	690	345	50,8	60,4	19
4	1/4"	220	310	165	690	345	50,8	60,4	19
4,5	1/4"	220	310	165	690	345	50,8	60,4	19
5	1/4"	165	205	80	690	275	50,8	60,4	19
5,5	1/4"	165	205	80	690	275	50,8	60,4	19
6	1/4"	165	205	80	690	275	50,8	60,4	19
5	1/2"	100	100	165	690	345	63,5	82,5	26
6	1/2"	100	100	165	690	345	63,5	82,5	26
7	1/2"	80	80	135	690	345	63,5	82,5	26
8	1/2"	80	80	135	690	345	63,5	82,5	26
9	1/2"	80	35	95	690	220	63,5	82,5	26
9,52	1/2"	80	35	95	690	220	63,5	82,5	26
12,7	3/4"	60	60	100	345	165	73	92	38
13	3/4"	55	55	55	275	165	73	92	38
14	3/4"	55	55	55	275	165	73	92	38
15	3/4"	55	55	55	275	165	73	92	38
15,87	3/4"	55	55	55	275	165	73	92	38
16	3/4"	55	55	55	275	165	73	92	38
17	3/4"	55	55	55	275	165	73	92	38

\* All pressure and vacuum rating are determined at 20°C  
 \*\*Tolerance of tube or probes diameter ± 0,127mm

### How to order 31271 TYPE

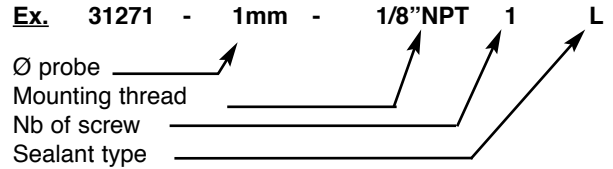

Ex. 31271- 1mm 1/8" NPT 1L

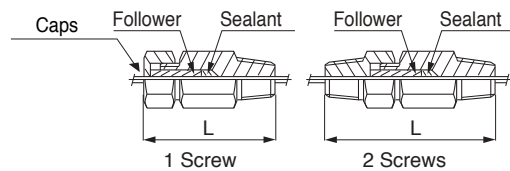

Sealant material	Torque table Nm						
	Ø Gland mounting thread NPT						
	1/16"	1/8"	1/4"	1/2"	3/4"	1"	1"1/4"
Neoprene	-	6,21 6,78	40,8 47,6	74,8 81,6	74,8 81,6	-	-
Viton	-	6,21 6,78	40,8 47,6	74,8 81,6	74,8 81,6	-	-
Teflon	0,79	6,21	20,4	74,8	122	407	407
Lava	1,02	6,78	27,2	81,6	136	441	441
Grafoil	-	6,21 6,78	46,6 54,4	122 136	122 136	-	-

## CHOOSING A CONTROLLER

The VULCANIC range of controllers covers the great majority of industry requirements. Following steps will help you to define the right controller.

- 1) define the desired control precision: if  $\pm 5^{\circ}\text{C}$ , choose an 'ON/OFF' controller ; for greater precision, consider a 'PID' appliance.
- 2) Know what kind of temperature input is used : PT100 - Thermocouple - Current - Voltage.
- 3) Know what kind of power supply device is to be driven, so as to choose the type of control output (usually called 'Output P/N.1'):
  - for a contactor, choose a controller with a 'relay' output
  - for a power unit, choose a controller with a "numeric" output
  - for a device with an analogic input (eg : motorised valve) choose a controller with an "Analogic" output.
- 4) Know what use will be made of the auxiliary outputs (usually called 'Output N°2 and N°3') : choose a "Relay" output to drive an alarm, "Current or Voltage" for a measurement repeater, and/or "Cold" output to drive an ON/OFF valve for a cooling system.

## 48x48 ON/OFF CONTROLLERS WITH 3-DIGIT DISPLAY

Class 0,2 controllers, large-size 3 digit display, lockable setting, configurable input (PT100 - J-, K-, T-type thermocouples), panel mounted or fastened to DIN rail. Supplied pre-set.

1 relay output, double-throw contacts, 2A/240V.

Supply voltage : 90 to 264 V - 50/60 Hz.

Weight 0,2 kg.



Depth : 100mm.

P/N.	Input	Temperature Range (°C)
30633-01	PT 100	-50 to 100°C
30633-51	PT 100	0 to 100°
30633-41	PT 100	-50 to 300°C
30633-12	TC/J	0 to 200°C
30633-22	TC/J	0 to 400°C
30633-02	TC/J	0 to 600°C
30633-03	TC/K	0 to 800°C

## 48x48 AUTOTUNE CONFIGURABLE PID TEMPERATURE CONTROLLERS

Autotune PID temperature controllers with 3 outputs.

**Configurable input :** RTD (PT100) or thermocouples type B/J/K/L/M/R/S/T, or analogic voltage 0/10 V, 2/10 V, 0/5 V, 1/5 V, 0 / 50 mV, 1/50 mV, or loop powered analogic current 0/20 mA, 4/20 mA.

**Main output on request :** SPDT relay 2 A / 240 VAC (on a resistive load) and pulse wave modulation 0/10 VDC for SSR (period 0,25 to 512 seconds / 20 mA max) configurable by strap, analog voltage 0/5 V, 0/10 V, 2/10 V or analogic current 0/20 mA, 4/20 mA (powered in 24 VDC).

**Output 2 and 3 on request :** same as output 1. Optional circuit board A : see table hereafter.

On/off optional control with adjustable differential, simultaneous display of measurement (red LED 8 mm high) and setpoint (green LED 6 mm high).

Selftuning available during switch on operation.

Supply voltage 100 to 240 VAC +/- 10% 50/60 Hz. Class 0,1.

Front panel to IP 66. Mass 0,21 kg.

Removable casing depth 110 mm, for cutting 45 X 45 mm.



Depth : 100mm.

P/N.	Old P/N.	Input	Temp.* range (°C)	Control output	Output 2	Output 3
30656-01	30655-01	PT 100	-50 to 350	Relay	Alarm	-
30656-02	30655-02	PT 100	-50 to 350	Logic	Alarm	-
30656-03	30655-03	PT 100	-50 to 350	Relay	Cold Relay	Alarm
30656-04	30655-04	PT 100	-50 to 350	Logic	Cold Relay	Alarm
30656-13	30655-13	TC/J	0 to 450	Relay	Alarm	-
30656-14	30655-14	TC/J	0 to 450	Relay	Cold Relay	Alarm
30656-15	30655-15	TC/J	0 to 450	Logic	Alarm	-
30656-16	30655-16	TC/J	0 to 450	Logic	Cold Relay	Alarm
30656-21	30655-21	TC/K	0 to 1200	Relay	Alarm	-
30656-23	30655-23	TC/K	0 to 1200	Logic	Alarm	-
30656-05	-	PT100	-50 to 350	Analogic	Alarm	-
30656-17	-	TC/J	0 to 450	Analogic	Alarm	-
30656-24	-	TC/K	0 to 1200	Analogic	Alarm	-

### Microcards for reconfiguring the appliance ( they are used for PID controllers type 30656 or 30881 )

30656-92	SPDT relay and PWM circuit board for main output
30656-96	Analog circuit board for main output ( voltage or current )
30656-90	SPDT relay circuit board for output 2 and 3
30656-91	Analog circuit board for output 2 or 3 ( voltage or current )
30656-99	PWM circuit board for output 2 or 3
30656-93	RS 485 circuit board, MODBUS or ASCII for option A
30656-97	Remote analog setpoint 0/5 VDC or 0/10 VDC or 2/10 VDC or 0/20mA or 4/20mA, for option A
30656-95	Setpoint selection by single pole contact for option A
30656-98	Power supply 24 VDC / 20 mA for cooled output

## 48x96 AUTOTUNE CONFIGURABLE PID TEMPERATURE CONTROLLERS

Autotune PID temperature controllers with 3 outputs.

**Configurable input :** RTD (PT100) or thermocouples type B/J/K/L/M/R/S/T, or analog voltage 0/10 V, 2/10 V, 0/5 V, 1/5 V, 0 / 50 mV, 1/50 mV, or loop powered analogic current 0/20 mA, 4/20 mA.

**Main output on request :** SPDT relay 2 A / 240 VAC (on a resistive load) and pulse wave modulation 0/10 VDC for SSR (period 0,25 to 512 seconds / 20 mA max) configurable by strap, analog voltage 0/5 V, 0/10 V, 2/10 V or analogic current 0/20 mA, 4/20 mA (powered in 24 VDC).

**Output 2 and 3 on request :** same as output 1.

Optional circuit boards A and B : see table above.

On/off optional control with adjustable differential, simultaneous display of measurement (red LED 8 mm high) and setpoint (green LED 6 mm high).

Selftuning available during switch on operation.

Supply voltage 100 to 240 VAC +/- 10% 50/60 Hz. Class 0,1.

Front panel to IP 66. Mass 0,27 kg.

Removable casing depth 100 mm, for cutting 45 X 92 mm.



P/N.	Input	Temperature range (°C)	Control output	Output 2	Output 3
30881-01	PT 100	-50 to 350	Relay	Alarm	-
30881-02	PT 100	-50 to 350	Logic	Alarm	-
30881-03	PT 100	-50 to 350	Relay	Cold Relay	Alarm
30881-04	PT 100	-50 to 350	Logic	Cold Relay	Alarm
30881-05	PT 100	-50 to 350	Analogic	Alarm	-
30881-13	TC/J	0 to 450	Relay	Alarm	-
30881-14	TC/J	0 to 450	Relay	Cold Relay	Alarm
30881-15	TC/J	0 to 450	Logic	Alarm	-
30881-16	TC/J	0 to 450	Logic	Cold Relay	Alarm
30881-17	TC/J	0 to 450	Analogic	Alarm	-
30881-21	TC/K	0 to 1200	Relay	Alarm	-
30881-23	TC/K	0 to 1200	Logic	Alarm	-
30881-24	TC/K	0 to 1200	Analogic	Alarm	-

### Microcards for reconfiguring the appliance

**30881-90** Circuit board for analogic remote setpoint : 0/5 VDC, 0/10 VDC, 2/10 VDC or 0/ 20 mA or 4/ 20 mA for option B, with local / remote switching by contact out of potential.



## 48 x 24 NUMERIC TEMPERATURE INDICATOR

Process magnitude or temperature indicators.

Input configurable for current :

(active or passive, zero assessed 20mA, 4/20 mA or other)

For low-level voltage (mV up to 2000) or high-level voltage (V up to 200, 0/10 V for instance), Potentiometer (200 ohm minimum), Stress gauges (5 V)

Frequency (0.25 Hz to 100 kHz), PT100 (2 or 3 or 4 wires) and thermocouples (B, E, J, K, R, S, T, N, W3 and W5)

Option 2 threshold alarm outputs by 260V/1A resistive inverter relay

Analogue measurement copy option, galvanic installation: current-configurable (active 0/20 mA, 4/20 mA or other) or for low-level voltage 0/10V (or other).

Display of four red digits + unit (configurable for °C, bar, rpm, lpm)

General-purpose power supply, 20 to 265 Vac or

DC. Connection to screw-on plug-in terminals



Depth: 84 mm, weight 0.18 kg, designed for recessing into a cutout measuring 92.5 x 42.5 mm.

### P/N.

**30828-01** basic model without options

**30828-02** model equipped with an analogue output

**30828-03** model equipped with two alarm outputs and one analogue output

**30828-04** kit: IP65 flexible protection

IP40 front panel: convertible to IP65 by the addition of flexible protection.

Other manufacturing possibilities: MODBUS / PROFIBUS instead of analogic output.

## 48x48 DIGITAL ON/OFF CONTROLLER

These indicators are smaller than the 48x96 devices but still offer similar functions to the larger models. Supplied pre-set and ready for use (as are most of our measuring devices), they can be reconfigured by the user if necessary. Universal thermocouple input, PT 100, mA and mV inputs.

Large red 4-digits display, 2 alarms on SPDT 2A at 120/240 VAC relays and measurement repeater (4/20mA) on certain models.

IP65 front face, supply voltage: 100 to 240 VAC.

Alarm status shown by LEDs on the front face.



Depth : 110mm.

### P/N.

P/N.	Input	Scale (°C)	Repeater	L (mm)	Weight (kg)
<b>30848-01</b>	T/C J	0 +761	No	110	0,2
<b>30848-02</b>	T/C K	-200 +1373	No	110	0,2
<b>30848-03</b>	PT 100	0 +800	No	110	0,2
<b>30848-04</b>	4/20mA	user-configured	No	110	0,2
<b>30848-11</b>	T/C J	0 +761	Yes	110	0,2
<b>30848-12</b>	T/C K	-200 +1373	Yes	110	0,2
<b>30848-13</b>	PT 100	0 +800	Yes	110	0,2
<b>30848-14</b>	4/20mA	user-configured	Yes	110	0,2

Temperature range can be altered by rekeying

## 48 x 96 TEMPERATURE CONTROLLER

Temperature indicators with 3 Digitals ON/OFF. Red 4-digit display and alarm indicators. Supplied pre-set (except P/N. 30856-1), but can be reconfigured by the user if necessary.

Alarm relays with SPDT contacts, 2A 120/240VAC, supply voltage 100 to 240 VAC

IP66 front face

ACCURACY ± 1unit 0,25% of the range



Depth : 100mm.

### P/N.

P/N.	Input	Temp. range* (°C)	Alarms Configurable	Weight (kg)
<b>30856-51</b>	Configurable	-200/+1373	3	0,6
<b>30856-61</b>	T/C J	0 / +761	3	0,4
<b>30856-62</b>	T/C K	-200 / +1373	3	0,4
<b>30856-63</b>	PT 100	0 / +800	3	0,4
<b>30880-91</b>	Analogue card for measurement repeater			

Temperature range can be altered by rekeying

## 48 x 48 PID TEMPERATURE CONTROLLER

Programmer with the same control characteristics as the 30656 models. Memory capacity for four programs of 16 chainable subroutines. Programming by speed or by time, in hours / minutes or minutes / seconds. Delayed start function. Program cycles can be set from 1 to 9999. Weight : 0,2 kg

Voltage: 100 to 240 VAC IP66



Depth : 110mm.

### P/N.

P/N.	Input	Temp. range* (°C)	Control output	Output 2	Output 3
<b>30635-01</b>	PT 100	0/+800	Relay	Alarm	Alarm
<b>30635-02</b>	PT 100	0/+800	Logic	Alarm	Alarm
<b>30635-13</b>	TC/J	0/761	Relay	Alarm	Alarm
<b>30635-15</b>	TC/J	0/761	Logic	Alarm	Alarm
<b>30635-21</b>	TC K	-20/+1371	Relay	Alarm	Alarm
<b>30635-23</b>	TC K	-20/+1371	Logic	Alarm	Alarm

Temperature range can be altered by rekeying

## IP65 PROTECTIVE FRONT FACES FOR CONTROLLERS and ADAPTOR PLATES

IP 65 front faces for 48x48 and 48x96 controllers and 96x48 indicators. These panels have transparent hinges and covers and allow upgrading to IP65 of any appliance which fits a standard aperture of 45 x 45 (for 48 x 48 models) or 45 x 92 (for 48 x 96 models).

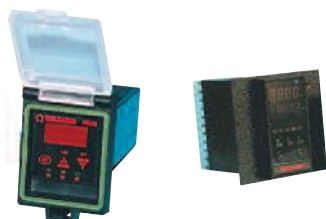

### P/N.

P/N.	Purpose	Original fitting	Controller format
<b>34848-99</b>	protection		48x48
<b>34896-99</b>	protection		48x96
<b>34896-48</b>	adaptor	48x96 --->	48x48
<b>39696-48</b>	adaptor	96x96 --->	48x48
<b>39696-96</b>	adaptor	96x96 --->	48x96

### CONNECTION PRINCIPLE FOR SOLID STATE RELAYS

Nominal powers given in the table are valid for an ambient temperature of 45°C max. They take into account the power accuracy of heating elements and variations in power supply voltage.

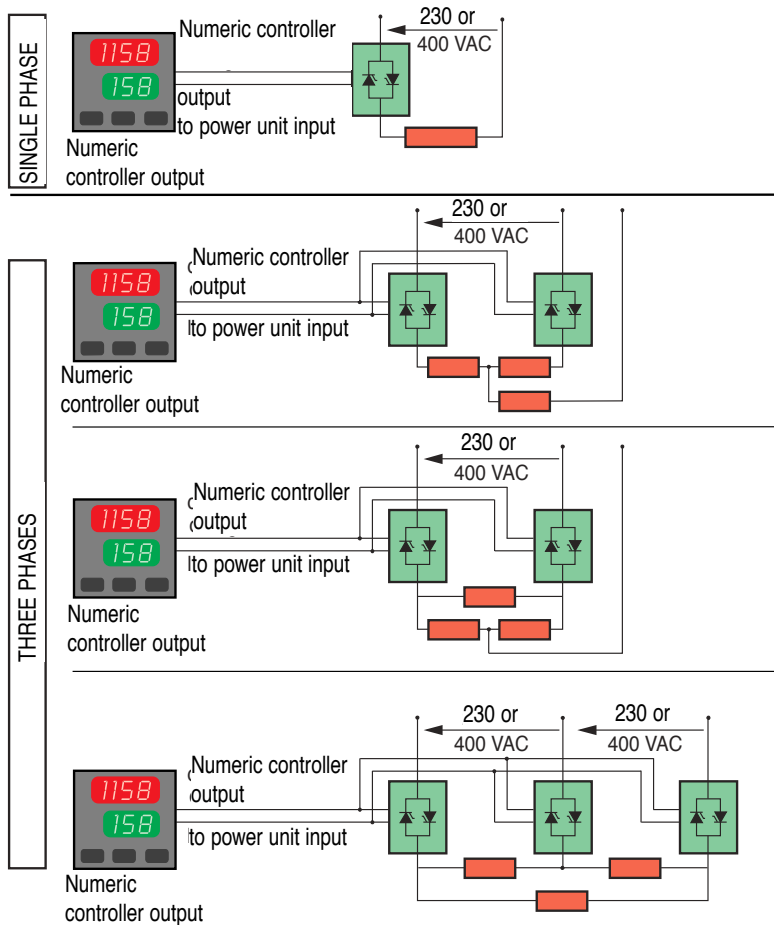

	Max. current UP	Nominal power	
		Single phase	Three phase
115 V	15 A	1,4 kW	2,5 kW
	25 A	2,4 kW	4,1 kW
	45 A	4,3 kW	7,5 kW
	75 A	7,2 kW	12,4 kW
	125 A	12,0 kW	20,7 kW
	200 A	19,2 kW	33,2 kW
	275 A	26,4 kW	45,6 kW
	400 A	38,3 kW	66,3 kW
230 V	15 A	3,0 kW	5,0 kW
	25 A	5,0 kW	8,3 kW
	45 A	8,6 kW	14,9 kW
	75 A	14,4 kW	24,9 kW
	125 A	24,0 kW	41,5 kW
	200 A	38,3 kW	66,3 kW
	275 A	52,7 kW	91,2 kW
	400 A	76,7 kW	132,7 kW
400 V	15 A	5,0 kW	8,6 kW
	25 A	8,3 kW	14,3 kW
	45 A	15,0 kW	25,7 kW
	75 A	25,0 kW	43,0 kW
	125 A	41,7 kW	72,0 kW
	200 A	66,7 kW	115,0 kW
	275 A	91,7 kW	158,0 kW
	400 A	133,3 kW	230,0 kW
500 A	166,7 kW	288,0 kW	

### 15, 25 and 45 A SINGLE PHASE SOLID STATE RELAYS

Single phase thyristor power units designed to drive resistive loads of up to 45 A.

A range of compact appliances meeting present-day industry requirements, fitting to symmetrical DIN rail. Much better suited than contactors to drive electric heaters, power units have no moving parts, no wear, and no maintenance; they have a higher switching rate, allowing better control of the output power.

Steering signal : 0/4 to 0/30VDC numeric input from a controller with numeric output.

Operating principle: pulse control. The thyristors start conducting when the voltage is 0V and stop when current is at zero (no interference).

Thyristor protection by RC circuit + varistor and ultra-fast fuse supplied.

Operating voltage :40 to 440VAC at 47 to 70 Hz.

A 24 V generator is needed to polarise the steering signal for power units with 4/20 mA analogic input.



Steering signal: 0/4 to 30 VDC numeric input, to be driven by a controller with numeric output, for single and three phase use.

P/N.	Max. current	L (mm)
30330-15	15 A	30
30330-25	25 A	30
30330-45	45 A	52

Pack of 5 spare ultra-fast fuses

P/N.	Current
30330-97	15 A
30330-98	25 A
30330-99	45 A

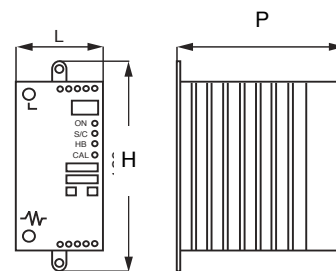

Steering signal: 4/20 mA analogic input from a controller with 4/20 mA output,

for breaking off only 1 phase

P/N.	Max. current	L/H/P (mm)
30330-65	15 A	52x120x120
30330-75	25 A	52x120x120
30330-95	45 A	52x120x120

For breaking off 2 phases

P/N.	Max current	L/H/P (mm)
30330-66	15 A	95x120x120
30330-76	25 A	95x120x120
30330-86	35 A	148x120x123
30330-96	45 A	148x120x159

For breaking off 3 phases

P/N.	Max current	L/H/P (mm)
30330-67	15 A	123x120x120
30330-77	30 A	148x120x123
30330-87	45 A	148x138x123

## THREE PHASE STATIC POWER UNITS FROM 75 à 500 A

These are thyristorized units capable of controlling 3-phase resistive load current levels according to a numeric input (0/5 à 0/30 VDC) or analogic input (0/10 VDC - 4/20 mA - 0/2,2 kohms), of a regulator.

Attaching to the back of the panel at a maximum temperature of 45°C.

Conduction by wave trains with energising at zero voltage and deenergizing at zero current without interference.

Load voltage : 24 à 440 VAC maxi.

These units have forced ventilation and a control card requiring a 230VAC single phase auxiliary power supply.

All the equipment is supplied with integrated ultrafast fuses.

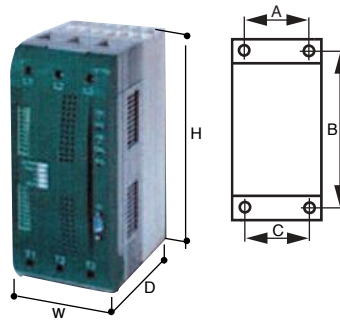

Fixing distant			
	A	B	C
75A et 125A	96	290	104
200A	60	335	60
275A à 500A	222	495	222

Models equipped with load monitoring come with an integrated current sensor. They trip a contact in the event of an anomaly affecting a fuse, thyristor, phase, load.

P/N. with logic input	P/N. with configurable analogue input and load monitoring	I max	P.Nominal at 400 V 3P at 45°C	Size H x W x D (mm)	Weight (kg)
30250-01	30250-41	75 A	43 kW	316 x 116 x 187	5
30250-02	30250-42	125 A	72 kW	316 x 116 x 187	5
30250-03	30250-43	200 A	115 kW	350 x 116 x 220	6,5
30250-04	30250-44	275 A	158 kW	520 x 262 x 270	15
30250-05	30250-45	400 A	230 kW	520 x 262 x 270	15
30250-06	30250-46	500 A	288 kW	520 x 262 x 270	15

Ultra fast spare fuses for power units : (bag of two)

P/N.	I max (A)	For P/N
30251-01	120	30250-x1
30251-02	200	30250-x2
30251-03	315	30250-x3
30251-04	315	30250-x4
30251-05	550	30250-x5
30251-06	315x2	30250-x6

If you need a power input with an analog input without load monitoring, order a logic input family unit and a signal converter reference. P/N. 30290-01

## ELECTROMECHANICAL POWER PROPORTION DEVICES

This device operates by the successive opening and closing of the power supply circuit with a period of around 20 seconds and a psychic ratio that is adjustable by a knob graduated from 0 to 100%. 230VAC single phase

Power supply  $\pm 10\%$  (2800 W maximum on resistive load) with voltage output and terminals for the connection of a display indicator light.

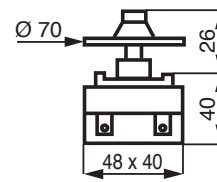

Bare model  
P/N. 9014-01  
(weight 0,11 kg).

Fig. A

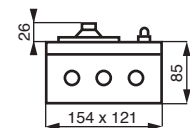

Model P/N.9014-02 • in protected case of aluminium alloy with the same properties as shown in A. fitted with switch and indicator light displaying the power supply of the load (weight 1kg).

## ELECTRONIC POWER PROPORTIONER AND CONVERTER

The power proportioner P/N. 30290-03 is capable of controlling any type of static power unit of prosthetic relayed by means of a 0/100% potentiometer.

Output signal : logic 0/10 VDC.

Power supply : 240 VAC.



The signal converter P/N. 30290-01 using an analog signal (4/20mA, 0.20VDC, 0/10VDC, 2,2kΩ), can generate a logic signal with a variable cyclic ratio of 0 to 100% to control power units or static relays.

Output signal : 0/10 VDC logic

Power supply : 240 VAC.

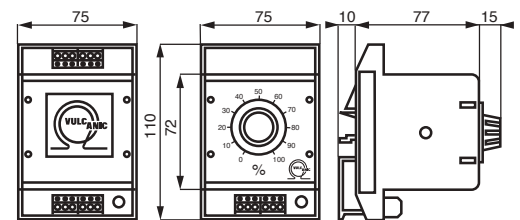

Power supply voltage : 240 VAC +10% -15% 50/60 Hz.

P/N.	Model
30290-03	Power proportioner
30290-01	Converter



## READY TO USE POWER SUPPLY AND CONTROL UNITS

Why reinvent something that VULCANIC, the specialist, has already designed? Why design and build when VULCANIC has already done it for you. You save time and money, and you get a guaranteed result. Our power supply and control units are easy to install, quick to commission, and perfectly suited to our heating systems. Don't hesitate : choose the appliance which suits your installation – a few datas are enough to choose the right model :

- Supply voltage
- Power to be delivered
- Control mode: ON/OFF or PID
- Power supply device: contactor or PU (power unit: silent, and better suited to heating elements).
- Number of outputs : number of appliances to be connected in parallel. Delivered with drawing and usual manual

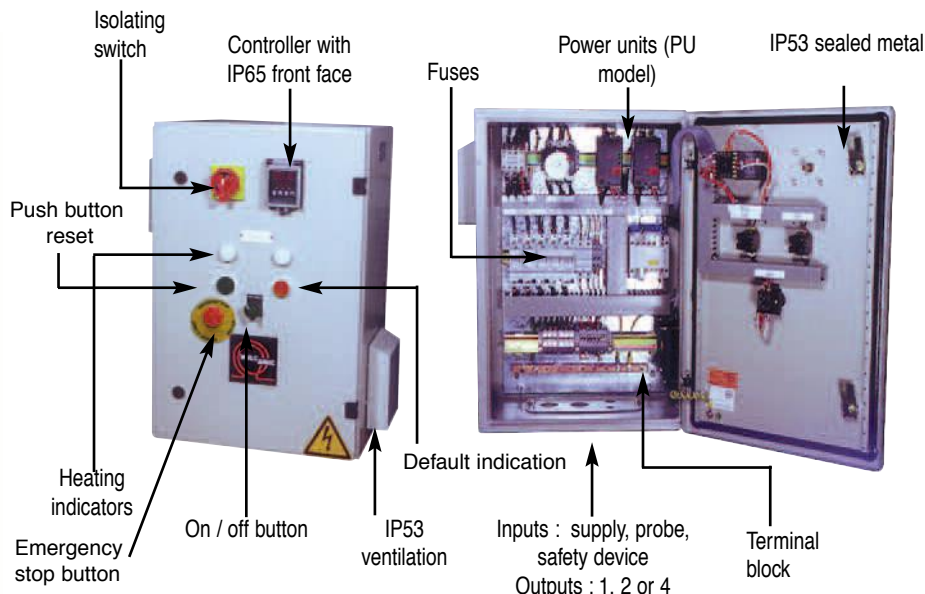

## CONTROL UNITS CUSTOMIZED

VULCANIC offers you, at a very competitive price, a number of standard control units, some of which are available on stock within 24 hours. If in spite of everything you can't find the unit which suits your application in the following pages, describe it using the adjacent form and send the details to our control specialist, who will do the calculations.

**Use:**  
**Power:** kW - **Voltage:** V single / three phases – **Number of control zones:** 1 / 2 / 3 / 4 and more  
**Control mode:** on/off / PID / programmer - **Input:** Pt100 / J-type thermocouple / K-type thermocouple / current / voltage  
**Power supply device :** Contactor / Power unit – **Number of outputs:** 1 / 2 / 3 / 4 and more.  
**Connected to a motor-pump or motor-fan unit:** yes / no  
**-> Power:** kW - **Voltage:** V single / three phases  
**Labelling and documentation in:** French / English / German

## CONTROL UNITS, PID 200W / 230V SINGLE PHASE/ 1A

Ready-to-use units for power supply and temperature control silicone heating panels, flexible heating elements, cartridge heaters, etc. These units are supplied in an IP53 metal box for wall mounting. They include a controller with IP65 front face, an on / off button with integral indicator light and load protection by fuse. Heating elements and probe are connected to a terminal block. Glands supplied.



Dimensions (mm): L =200- H = 250 - D = 136.

P/N.	Input	Controller	Temp range
32032-11	Pt100	PID	0/+300°C
32032-12	TC/J	PID	0/+450°C
32032-13	TC/K	PID	0/+1200°C

## CONTROL UNITS, 3 AND 5 KW / 230V SINGLE PHASE

Ready-to-use units for power supply and temperature control silicone heating panels, flexible heating elements, cartridge heaters, etc. These units are supplied in an IP55 polyamid box. They are equipped with an auto-adaptive PID controller type 30656 class 0.2 with a alarm available, a remote controle and have 2 terminals for external safety circuit



These units are supplied in an IP55 metal box for wall mounting. They include a controller with IP65 front face, an on / off button with integral indicator light and load protection by fuse. Heating elements and probe are connected to a terminal block. Glands supplied. The simple control unit have 2 terminals for external safety circuit.

The control unit with integral safety temperature cut-out have 2 terminals for external safety circuit, and a safety temperature cut-out (K-type thermocouple input) to protect the heating elements from damage due to overheating.

Dimensions (mm): L = 400 - H = 400 - D = 200.

Technical advice: Solid-state relay models are preferable.

P/N.	P max. (kW)	Input	Controller	Supply device	Temp. range
32045-20	3	TC/J	PID	UP SSR	0/+450°C
32045-21	3	TC/K	PID	UP SSR	0/+1200°C
32045-22	3	Pt100	PID	UP SSR	-50/+350°C
P/N.	P max. (kW)	Input	Controller	Supply device	Temp. range
32045-03	3	TC/J	PID	Solid-state relay	0/450°C
32045-12	3	Pt100	PID	Solid-state relay	0/300°C
32045-51	5	TC/J	ON/OFF	Contactor	0/450°C
32045-53	5	TC/J	PID	Solid-state relay	0/450°C
32045-61	5	Pt100	PID	Contactor	0/300°C
32045-62	5	Pt100	PID	Solid-state relay	0/300°C

### WITH INTEGRAL SAFETY TEMPERATURE CUT-OUT

Only for heating systems fitted with a safety K-type thermocouple

P/N.	P max. (kW)	Input	Controller	Device	Temp. range
32045-54	5	TC/J	PID	Solid-state relay	0/450°C
32045-55	5	Pt100	PID	Solid-state relay	0/300°C

The model with a J-type thermocouple input can be reconfigured on plant to a K-type input.

## THERMOSTAT CONTROL UNITS

Ready-to-use units for power supply and temperature control silicone heating panels, flexible heating elements, cartridge heaters, etc. These units are supplied in an IP55 metal box for wall mounting. They include front face an on / off button with integral indicator light and load protection by fuse. Heating elements are connected to a terminal block. Glands supplied.



P/N.	P max. (kW)	Voltage 3P	Supply device	Dimensions (mm)		
				Width	Height	Depth
32032-01	18	400	Contactor	300	400	200
32032-02	45	400	Contactor	400	400	200

## CONTROL UNITS, 8,6 kW to 158 kW at 400V, 3 phases with controller

Control units for temperature control of circulation liquid heaters, immersion heaters, fan heaters and duct heaters. Metal IP53 case.

They comprise a controller with IP65 front face, an isolating switch + fuses + power supply device (and its safety device, if a static power unit) + on / off indication + heating indications + safety fuses + emergency stop button + red default indicator + reset push button.

2 terminals for external safety circuit.

External safety module on 2 inputs terminal.

Pre-set controller.

Heating elements and probe are connected to a terminal block. Cable entry to box via supplied glands.

PART NUMBERS			Max. Power	Voltage (V)	Controller	Supply device	Dimensions			
PT100	J-type T/C	K-type T/C					Width	Height	Depth	
32065-05	32066-05	32067-05	8,6 kW	400 3 P	ON/OFF	Contactor	1	400	600	300
32065-07	32066-07	32067-07	8,6 kW	400 3 P	PID	Solid-state relay	1	400	600	300
32065-11	32066-11	32067-11	14,3 kW	400 3 P	ON/OFF	Contactor	1	400	600	300
32065-13	32066-13	32067-13	14,3 kW	400 3 P	PID	Solid-state relay	1	400	600	300
32065-14	32066-14	32067-14	14,3 kW	400 3 P	ON/OFF	Contactor	2	400	600	300
32065-16	32066-16	32067-16	14,3 kW	400 3 P	PID	Solid-state relay	2	400	600	300
32065-21	32066-21	32067-21	25,7 kW	400 3 P	ON/OFF	Contactor	1	400	600	300
32065-23	32066-23	32067-23	25,7 kW	400 3 P	PID	Solid-state relay	1	400	600	300
32065-24	32066-24	32067-25	25,7 kW	400 3 P	ON/OFF	Contactor	2	400	600	300
32065-26	32066-26	32067-26	25,7 kW	400 3 P	PID	Solid-state relay	2	400	600	300
32065-27	32066-27	32067-27	25,7 kW	400 3 P	ON/OFF	Contactor	4	600	800	300
32065-29	32066-29	32067-29	25,7 kW	400 3 P	PID	Solid-state relay	4	600	800	300
32065-41	32066-41	32067-41	43 kW	400 3 P	ON/OFF	Contactor	1	600	800	300
32065-43	32066-43	32067-43	43 kW	400 3 P	PID	Solid-state relay	1	600	800	300
32065-44	32066-44	32067-44	43 kW	400 3 P	ON/OFF	Contactor	2	600	800	300
32065-46	32066-46	32067-46	43 kW	400 3 P	PID	Solid-state relay	2	600	800	300
32065-47	32066-47	32067-47	43 kW	400 3 P	ON/OFF	Contactor	4	600	800	300
32065-49	32066-49	32067-49	43 kW	400 3 P	PID	Solid-state relay	4	600	800	300
32065-61	32066-61	32067-61	72 kW	400 3 P	ON/OFF	Contactor	1	600	800	300
32065-63	32066-63	32067-63	72 kW	400 3 P	PID	Solid-state relay	1	600	1200	300
32065-64	32066-64	32067-64	72 kW	400 3 P	ON/OFF	Contactor	2	600	800	300
32065-66	32066-66	32067-66	72 kW	400 3 P	PID	Solid-state relay	2	600	1200	300
32065-67	32066-67	32067-67	72 kW	400 3 P	ON/OFF	Contactor	4	600	1200	300
32065-69	32066-69	32067-69	72 kW	400 3 P	PID	Solid-state relay	4	600	1200	300
32065-91	32066-91	32067-91	115 kW	400 3 P	ON/OFF	Contactor	1	600	1200	300
32065-93	32066-93	32067-93	115 kW	400 3 P	PID	Solid-state relay	1	600	1200	300
32065-94	32066-94	32067-94	115 kW	400 3 P	ON/OFF	Contactor	2	600	1200	300
32065-96	32066-96	32067-96	115 kW	400 3 P	PID	Solid-state relay	2	600	1200	300
32065-97	32066-97	32067-97	115 kW	400 3 P	ON/OFF	Contactor	4	600	1200	300
32065-99	32066-99	32067-99	115 kW	400 3 P	PID	Solid-state relay	4	600	1200	300
32065-81	32066-81	32067-81	158 kW	400 3 P	PID	Solid-state relay	1	800	2000	400
32065-82	32066-82	32067-82	158 kW	400 3 P	PID	Solid-state relay	2	800	2000	400
32065-83	32066-83	32067-83	158 kW	400 3 P	PID	Solid-state relay	4	800	2000	400



### Temperature ranges

Factory set, user-configurable

Input	Control mode	Range
PT100	ON/OFF	-50/150
PT100	PID	0/300
TC J	ON/OFF	0/400
TC J	PID	0/450
TC K	ON/OFF	0/800
TC K	PID	0/1371

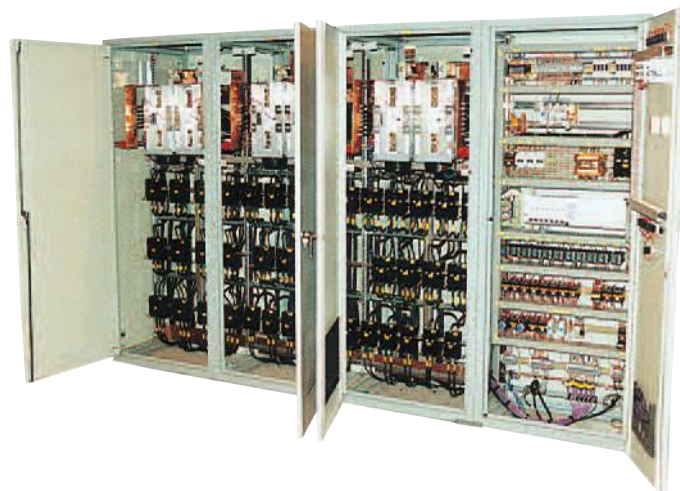



## NICKEL-CHROME RESISTANCE WIRE

Resistive wires for making up wire-bare heating elements. They are generally used for making coil-wound heating elements and their resistivity of  $1,08 \Omega \text{ mm}^2/\text{m}$  hardly changes at all with temperature. Their ends should be welded to steel or stainless steel pins which act as unheated conductors; they can equally well be doubled and twisted.



These reference numbers are for 10m lengths.  
Order x P/N. to receive x times 10 m of wire.

P/N.	Wire Ø (mm)	Resistance (Ω/m) ±5%	Weight (kg)
4503-06	0,40	8,59	0,010
4503-07	0,50	5,5	0,016
4503-08	0,56	4,38	0,020
4503-09	0,63	3,46	0,026
4503-10	0,71	2,73	0,033
4503-11	0,80	2,15	0,042
4503-12	0,90	1,7	0,053
4503-13	1	1,36	0,065
4503-14	1,12	1,1	0,082
4503-15	1,25	0,88	0,102
4503-16	1,40	0,702	0,128
4503-17	1,60	0,537	0,167

## GLASS FIBRE SHEATHING

This sheathing is made of 1 or 2 overlapping layers, silicone treated to avoid fragility, and is suited for insulating conductors at an ambient temperature up to 250°C (300°C peak temperature).

P/N. P/N. 2510-01 is not silicone treated (.2513- XX is double thickness.)



P/N.	Inside Ø (mm)	Outside Ø (mm)	Length (m)	Weight (kg)
2510-01	1,5	3	100	0,44
2511-01	3	6	50	0,88
2512-01	5	7	50	1,46
2513-01	8	10	50	0,86
2513-02	12	14	20	1,20

## STRANDED COPPER WIRE IN A GLASS FIBRE SHEATH

These conductors are made of small-diameter copper wires and are suited for connecting electrical heating elements at ambient temperatures up to 150°C (200°C peak temperature).



P/N.	Section (mm <sup>2</sup> )	Outside Ø wire (mm)	Inside Ø sheath (mm)	Roll length (m)	I <sub>max</sub> at 80°C (A)	Weight (kg)
2520-03	0,5	0,9	2,1	20	3,5	0,20
2520-05	0,75	1,2	2,3	20	6	0,24
2520-01	1,5	1,6	2,7	20	12	0,39
2520-04	2,5	2	3,2	20	16	0,59
2521-01	4	2,6	4	20	20	1,01
2521-02	6	3,6	4,8	20	27	1,30

## STRANDED NICKEL WIRE IN A GLASS FIBRE SHEATH

These conductors are made of 0,3 mm Ø pure nickel wires surrounded by an insulating sheath and are suited for connecting electrical heating elements at ambient temperatures up to 300°C (350°C peak temperature).



P/N.	Section (mm <sup>2</sup> )	Outside Ø wire (mm)	Inside Ø sheath (mm)	Roll length (m)	I <sub>max</sub> at 80°C (A)	Weight (kg)
2525-01	0,42	0,9	1,5	20	3,9	0,20
2525-02	0,75	1,2	2,6	20	7	0,27
2526-01	1,5	1,6	2,9	20	11	0,40
2526-02	2,5	2,0	3,4	20	15	0,60
2526-03	4	2,6	4,2	20	22	0,90

## STRANDED NICKEL WIRE IN A KAPTON SHEATH

These conductors are made of 0,3 mm Ø pure nickel wires surrounded by an insulating sheath and are suited for connecting electrical heating elements at ambient temperatures up to 350°C (400°C peak temperature).



P/N.	Section (mm <sup>2</sup> )	Outside Ø wire (mm)	Inside Ø sheath (mm)	Roll length (m)	I <sub>max</sub> at 80°C (A)	Weight (kg)
2527-01	2,5	2	2,5	20	15	0,625
2527-02	4	2,6	3	20	22	1,060

## EYELET TERMINALS IN PURE NICKEL

Allow nickel or copper leads to be connected to threaded terminals at an ambient temperature up to 650°C. Fixing by brazing or crimping



P/N.	Terminal Ø (mm)	Section (mm <sup>2</sup> )	Pack of	Weight (kg)
55340-10	5	1,25 à 2,5	10	0,012
55341-10	6	1,25 à 2,5	10	0,016
55342-10	5	3 à 6	10	0,015
55343-10	6	3 à 6	10	0,020

## STEATITE BEADS

Steatite beads allowing insulation of bare stranded ropes or under fibreglass insulator sheath or under kapton sheath, in 350 to 450°C environment.



To make an extension cord for infrared emitters type 6020, use the beads P/N 2530-03. A similar extension cord can be made up from beads P/N 2530-05 for ceramic insulated strip heaters type 4033.

P/N.	Ø inner (mm)	Ø outer (mm)	Length unit. (mm)	Nb of beads per m.	Nb of beads per packet	Weight (kg)
2530-01	1	3	3	390	4000	0,3
2530-02	1,5	4	4	280	3300	0,3
2530-03	2,2	5	5	260	3750	0,6
2530-04	3,2	6,5	6	230	2460	0,6
2530-05	3,8	8	7,7	200	2500	1
2530-06	4,7	8,5	9,5	150	1600	1
2530-07	6,7	10,5	9	140	1150	1

## CERAMIC TERMINALS

Enable the interconnection between two conductors (often inside protective boxes) at ambient temperatures up to 200°C. Bipolar models for single phase and tripolar models for 3 phases or single phase + earth.



P/N.	Type (mm)	Dimensions (mm <sup>2</sup> )	Section (mm)	Ø max (A)	I	Packaging	Weight (kg)
52486-10	2 poles	24x21x17	4	3	10	par 10 p.	0,16
52487-10	3 poles	35x21x17	4	3	10	par 10 p.	0,21
52488-05	2 poles	35x30x23	10	6	30	par 5 p.	0,24
52489-05	3 poles	51x30x23	10	6	30	par 5 p.	0,37





**ELECTRICAL HEATING AND COOLING  
SOLUTIONS  
FOR THE INDUSTRY**

**VULCANIC SAS**  
ZI des Chanoux  
48, rue Louis Ampère  
F-93330 Neuilly sur Marne  
France  
Tel. : +33 1 49 44 49 20



**VULCANIC SAS**  
ZI la Saunière  
F-89600 Saint Florentin  
France  
Tel. : +33 1 49 44 49 20



**VULCANIC UK Ltd**  
South Green Park Entreprise  
Centre, Mattishall  
NR20 3JY, Dereham Norfolk  
United Kingdom  
Tel. : +44 1603 340015



**LOREME SAS**  
12, rue des Potiers d'Étain  
Actipôle Borny  
F-57071 Metz  
France  
Tel. : +33 3 87 76 32 51



**VULCANIC SA**  
Heilig Hartstraat, 14  
B-2600 Berchem  
Belgium  
Tel. : +32 3 286 70 30



**RS ISOLSEC SAS**  
45, avenue des acacias  
F-45120 Cepoy  
France  
Tel. : +33 2 38 85 62 62



**VULCANIC TERMOELÉCTRICA SLU**  
Ctra. a Viérnoles, 32  
E-39300 Torrelavega  
Spain  
Tel. : +34 942 80 35 35



**VULCANIC GmbH**  
Donaustraße 21  
D-63542 Hanau  
Germany  
Tel. : +49 6181 9503 0



**RS ISOLSEC SLU**  
Ave Riu Mogent, 5  
E-08170 Montornes del valles  
Spain  
Tel. : +34 93 568 73 10



**VULCANIC Russia**  
105005 Moscow  
radio street  
house 24 building 1  
Russia  
Tel. : + 7 (903) 967-95-68



**VULCANIC TRIATHERM GmbH**  
Flurstraße 9  
D-96515 Sonneberg  
Germany  
Tel. : +49 3675 4083-0



**[www.vulcanic.com](http://www.vulcanic.com)**

